

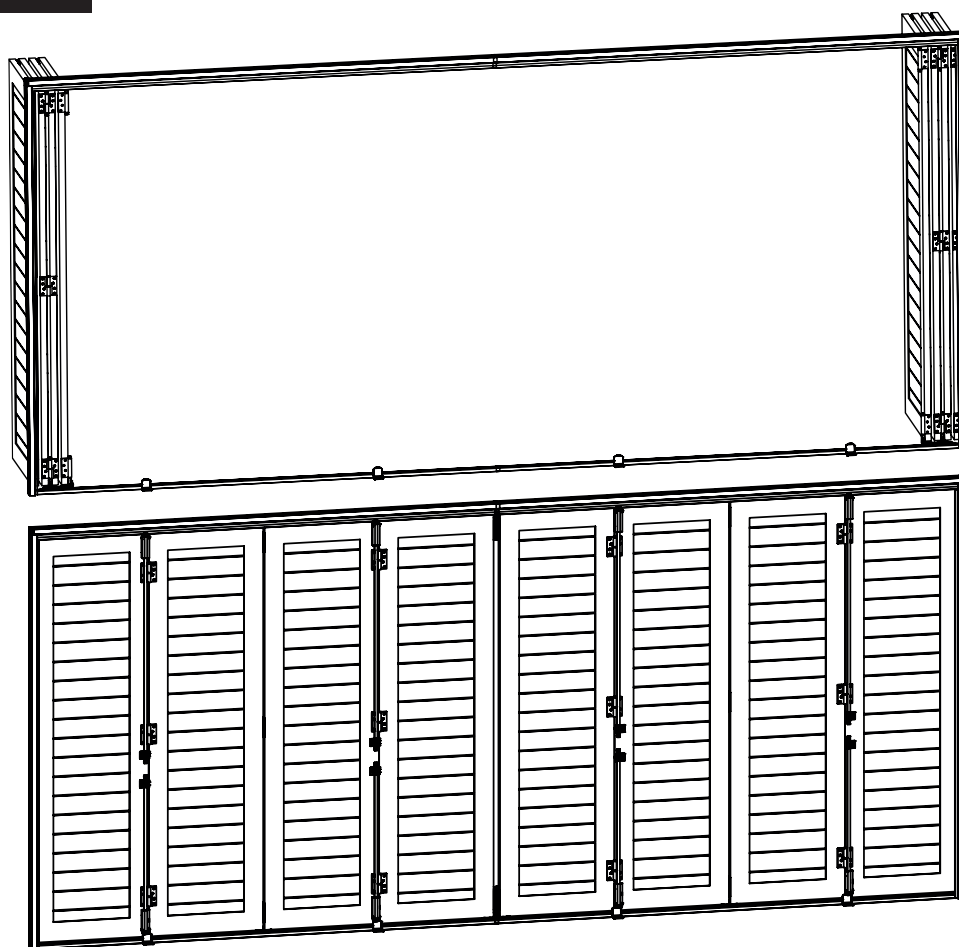

# Istruzioni di posa



Vista dall'interno



## Gamma VCP300

Ferramenta per persiane scorrevoli ripieghevoli  
Per configurazione 4+4

# Componenti

## PROFILI E ACCESSORI PER TELAIO IN ALLUMINIO

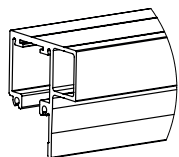

**A** VR10906

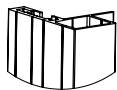

**B** VR10917

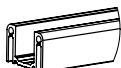

**C** VR10926

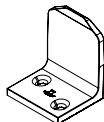

**D** VR10930

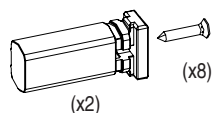

**E** VR10830

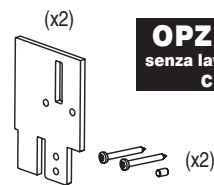

**T** VR10918

**OPZIONE**  
senza lavorazione  
CNC

## SCORRIMENTO SUPERIORE

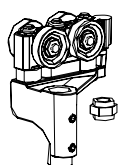

**F1** VR10100G

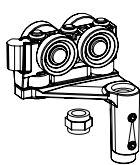

**F2** VR10200D

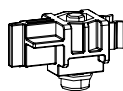

**G** VR10300

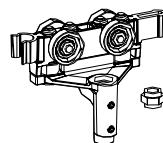

**H1** VR10700G

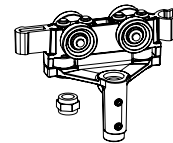

**H2** VR10600D

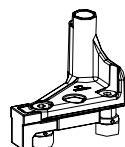

**I1** VR10400G

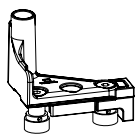

**I2** VR10500D

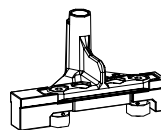

**J1** VR10800G

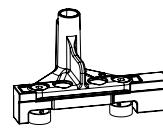

**J2** VR10801D

## COLLEGAMENTO PROFILI/ANTE

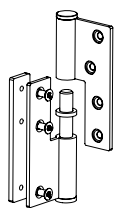

**K1** VR10821G

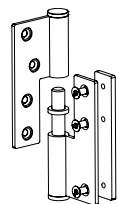

**K2** VR10822D

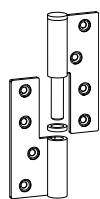

**L1** VR10809G

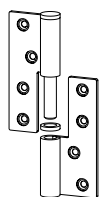

**L2** VR10810D

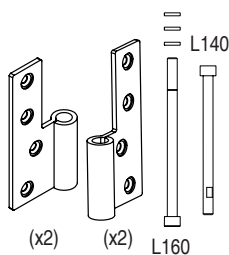

**M** VR10828

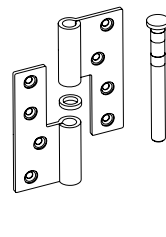

**N1** VR10816G

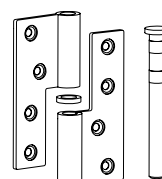

**N2** VR10817D

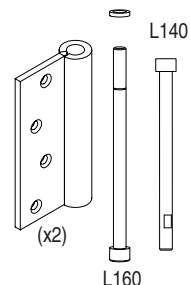

**O** VR10818

## CHIUSURA

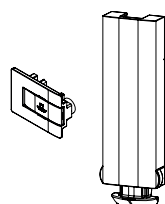

**P** VR10835



**Q** VR10837

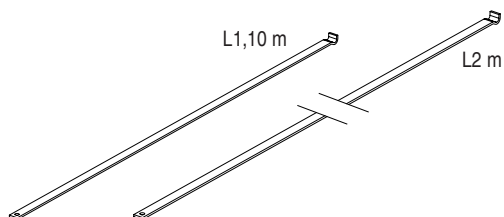

**R** VR10838J

**S** VR10839J

Descrizione		Codice	Conf.	H anta < 1800 mm	1800 <= H anta > 2800 mm	2800 <= H anta > = 3000 mm
				4+4	4+4	4+4
				Unità	Unità	Unità
<b>PROFILI E ACCESSORI PER TELAIO IN ALLUMINIO</b>						
<b>A</b>	BINARIO SUPERIORE IN ALLUMINIO 6M	VR10906	9	1	1	1
<b>B</b>	PROFILO TELAIO LATERALE CON BATTUTA IN ALLUMINIO 6 M	VR10917	9	1	1	1
<b>C</b>	GUIDA A U INFERIORE IN ALLUMINIO 6M	VR10926	9	1	1	1
<b>D</b>	BATTUTA INFERIORE ZAMA PER GUIDA A U INFERIORE	VR10930	1	4	4	4
<b>E</b>	KIT 2 BATTUTE FISSE NYLON PER GUIDA INFERIORE + VITI	VR10830	1	1	1	1
<b>T</b>	KIT 2 PIASTRE DI GIUNZIONE PER CONTROTELAIO	<b>OPZIONE senza lavorazione CNC</b> VR10918	1	1	1	1
<b>SCORRIMENTO SUPERIORE</b>						
<b>F1</b>	CARRELLO SUPERIORE ESTERNO SINISTRO VISTA INTERNA	VR10100G	1	1	1	1
<b>F2</b>	CARRELLO SUPERIORE ESTERNO DESTRO VISTA INTERNA	VR10200D	1	1	1	1
<b>G</b>	BATTUTA CARRELLO SUPERIORE NYLON	VR10300	1	2	2	2
<b>H1</b>	CARRELLO SUPERIORE CENTRALE SINISTRO ZAMA	VR10700G	1	1	1	1
<b>H2</b>	CARRELLO SUPERIORE CENTRALE DESTRO ZAMA	VR10600D	1	1	1	1
<b>SCORRIMENTO INFERIORE</b>						
<b>I1</b>	SLITTA INFERIORE TERMINALE SINISTRA VISTA INTERNA	VR10400G	1	1	1	1
<b>I2</b>	SLITTA INFERIORE TERMINALE DESTRA VISTA INTERNA	VR10500D	1	1	1	1
<b>J1</b>	SLITTA INFERIORE CENTRALE SINISTRA VISTA INTERNA	VR10800G	1	1	1	1
<b>J2</b>	SLITTA INFERIORE CENTRALE DESTRA VISTA INTERNA	VR10801D	1	1	1	1
<b>COLLEGAMENTO PROFILI/ANTE</b>						
<b>K1</b>	POMELLA PER TELAIO DESTRA VISTA INTERNA	VR10821G	1	2	3	4
<b>K2</b>	POMELLA PER TELAIO SINISTRA VISTA INTERNA	VR10822D	1	2	3	4
<b>L1</b>	POMELLA CENTRALE PIATTA SINISTRA	VR10809G	1	4	6	8
<b>L2</b>	POMELLA CENTRALE PIATTA DESTRA	VR10810D	1	4	6	8
<b>M</b>	2 SET DI 2 MEZZE POMELLE CARRELLO CENTRALE + VITI	VR10828	1	2	2	2
<b>N1</b>	POMELLA CENTRALE DI MEZZO SINISTRA + PERNO AMOVIBILE + RONDELLE	VR10816G	1	-	1	2
<b>N2</b>	POMELLA CENTRALE DI MEZZO DESTRA + PERNO AMOVIBILE + RONDELLE	VR10817D	1	-	1	2
<b>O</b>	2 MEZZE POMELLE TERMINALI + VITI	VR10818	1	2	2	2
<b>CHIUSURA</b>						
<b>P</b>	KIT CHIAVISTELLO PIATTO + GUIDA ASTA NYLON NERO	VR10835	10	8	8	8
<b>Q</b>	GUIDA ASTA + MANIGLIETTA ERGONOMICA NYLON NERO	VR10837	10	-	8	8
<b>R</b>	ASTA ALLUMINIO 1,10M PER CHIAVISTELLO PIATTO	VR10838J	10	8	8	4
<b>S</b>	ASTA ALLUMINIO 2M PER CHIAVISTELLO PIATTO	VR10839J	10	-	-	4

# INFORMAZIONI

## Attrezzi Necessari

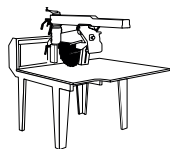

Sega circolare

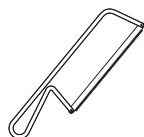

Seghetto per metallo

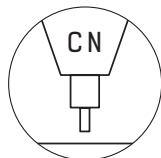

Chiave a brugola 2,5 e 8



Lima

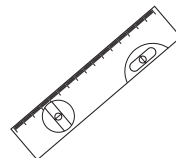

Livella

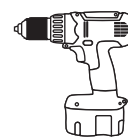

Trapano / Avvitatore



Punta per metallo

Ø13 mm  
Ø10 mm  
Ø7 mm  
Ø4,5 mm



Cacciavite

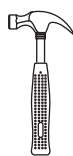

Martello

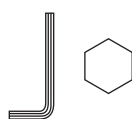

Chiave a brugola T20 e T25

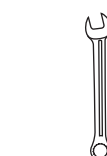

Chiave combinata 14



Frenafilietti

## Caratteristiche tecniche

Larghezza massima : 500 mm

Altezza massima : 3 000 mm

Sbordo su facciata : 500 mm maxi.

Peso fino a 20kg / anta

Spessore : da 30 a 35 mm

## Consigli

TORBEL declinerà ogni responsabilità se verranno montati componenti non previsti e non appartenenti a questa gamma. È compito del fabbricante assicurarsi che i componenti siano compatibili con le persiane. Il sistema dovrà essere posato da un professionista a regola d'arte rispettando tutte le NTC. Escludere la posa in prima linea costiera e nelle zone più ventose (Norma EN1991-1-4).

Rispettare le dimensioni massime per anta (3 m x 0,5 m x uno spessore compreso tra 30 e 35 mm) per un peso massimo di 20 kg per anta. Per il corretto funzionamento verificare che la struttura delle ante sia sufficientemente rigida e solida. Fissare saldamente il telaio (su una struttura sufficientemente resistente alle sollecitazioni del sistema) nei differenti singoli punti (i singoli punti si trovano a livello delle pomelle, delle battute inferiori e dei carrelli anta aperti e chiusi...) con la viteria adatta al sistema e al materiale della facciata. Utilizzare un fissaggio in ogni foro delle pomelle e dei chiavistelli previsti con la viteria adatta (vite per legno TF Ø5 o rivetto Ø4,8) in base al tipo di anta.

Prevedere delle aperture necessarie a far evacuare l'acqua soprattutto nella guida inferiore.

Il sistema si dovrà aprire e chiudere senza particolare sforzo (nessun attrito) e assicurarsi che non ci sia alcun ostacolo. Pulire e lubrificare regolarmente le pomelle e le ruote dei carrelli e delle guide inferiori. Sostituire i pezzi che presentano delle anomalie (usure importanti, rotture).

Verificare regolarmente la viteria, stringere o sostituire al bisogno.

Gli utenti sono tenuti a chiudere le persiane in caso di assenza e/o di avviso di vento forte (allerta arancione). Assicurarsi che i chiavistelli automatici siano posizionati correttamente quando le persiane sono chiuse, altrimenti aggiustarle manualmente.

È compito del produttore fornire all'utilizzatore finale i consigli di utilizzo e di pulizia dei nostri prodotti.

**Altezza Anta = Altezza telaio - 87 mm**

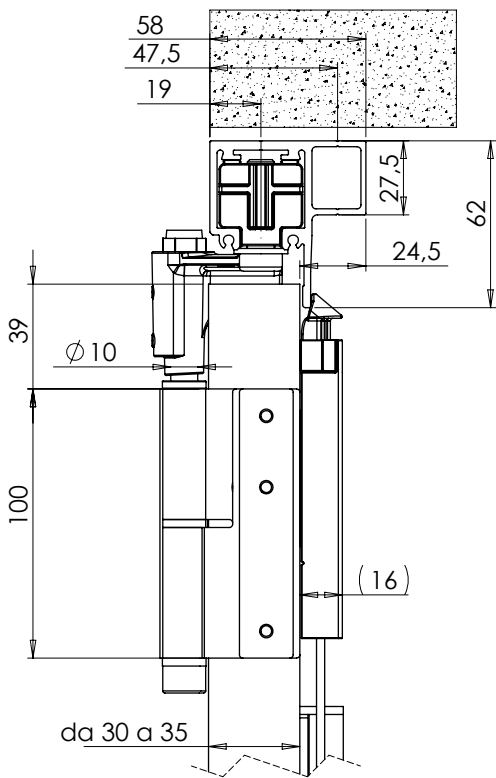

Lato esterno

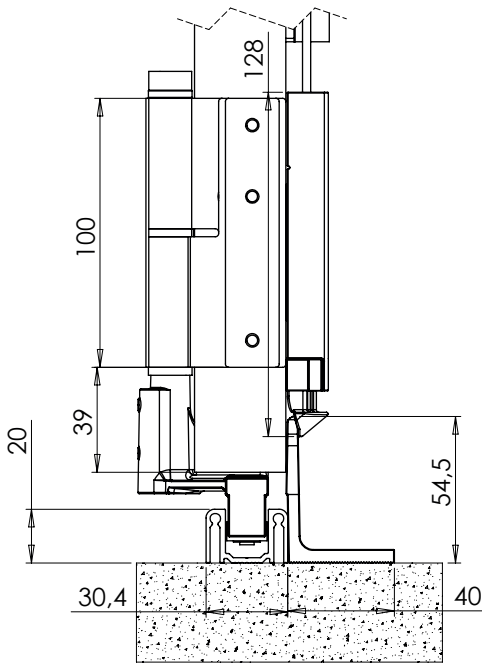

Lato interno

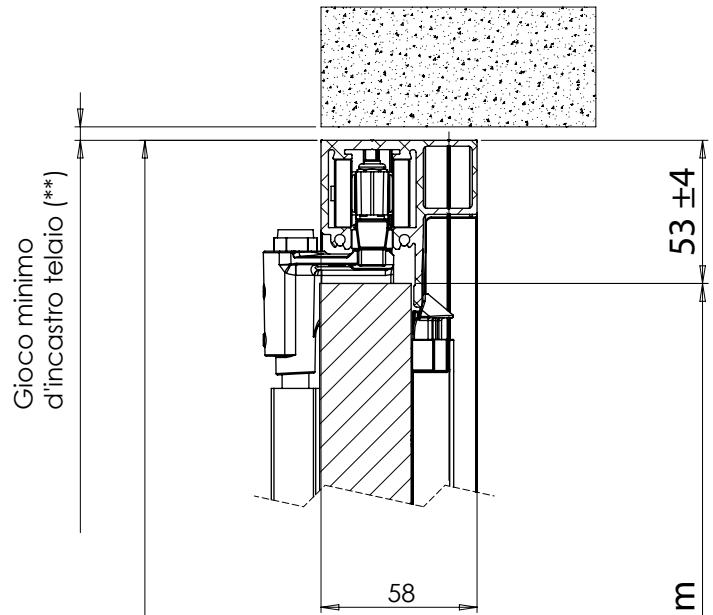

Gioco minimo d'incastro (\*\*)

Altezza telaio

Altezza Anta = Altezza telaio - 87 mm

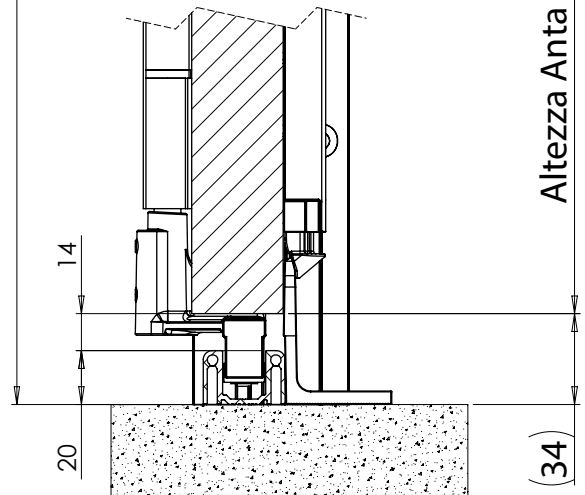

Lato esterno

Lato interno

(\*\*) Sulle aperture di dimensioni minime suggeriamo un gioco minimo di incastro periferico del telaio di 5 mm

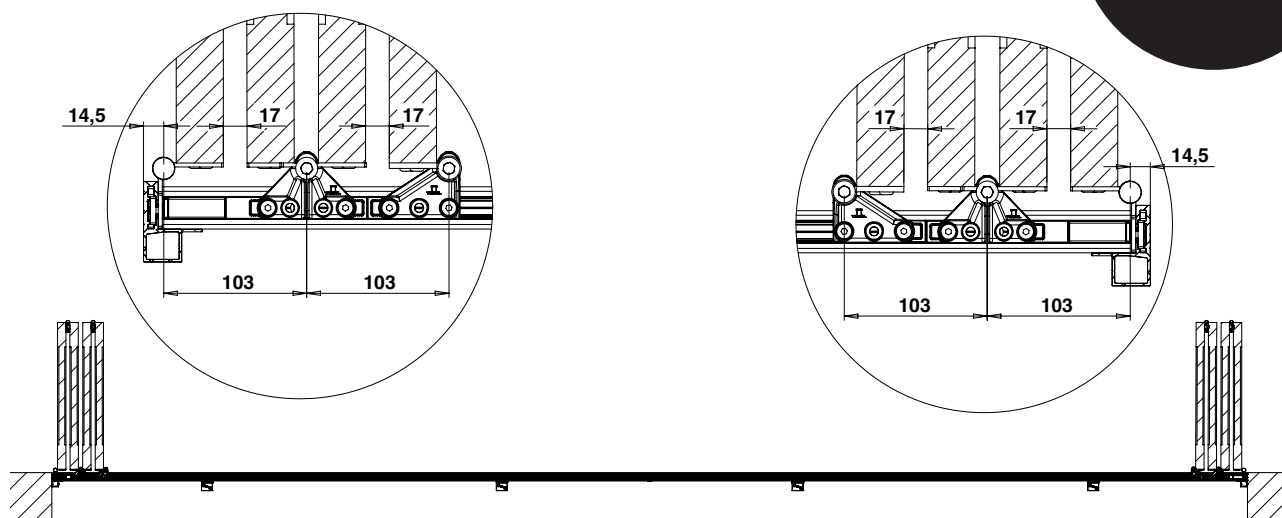

INTERNO



LATO ESTERNO

Gioco minimo di incastro telaio (\*\*)  
 $J = \text{Gioco di funzionamento (*)}$

Gioco minimo di incastro telaio (\*\*)

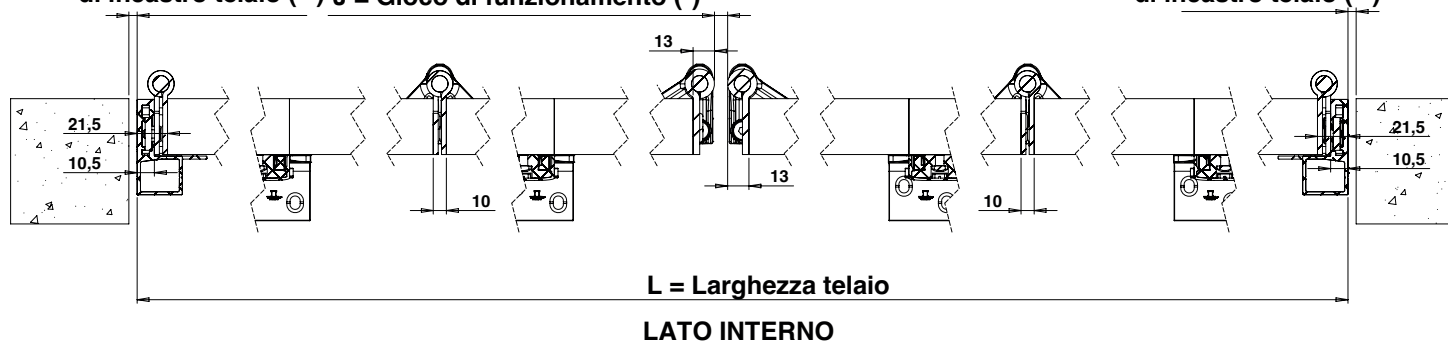

(\*) Il gioco di funzionamento J deve integrare l'arretramento del carrello durante la chiusura, le tolleranze dimensionali delle ante e del telaio nonché le dilatazioni legate alle variazioni igrometriche e termiche.

(\*) Arretramento del carrello: Larghezza anta 500 mm => 5 mm, 400 mm => 6.5 mm, 300 mm => 8.5 mm, 200 mm => 13 mm.

(\*\*) Sulle aperture di dimensioni minime suggeriamo un gioco minimo di incastro periferico del telaio di 5 mm.

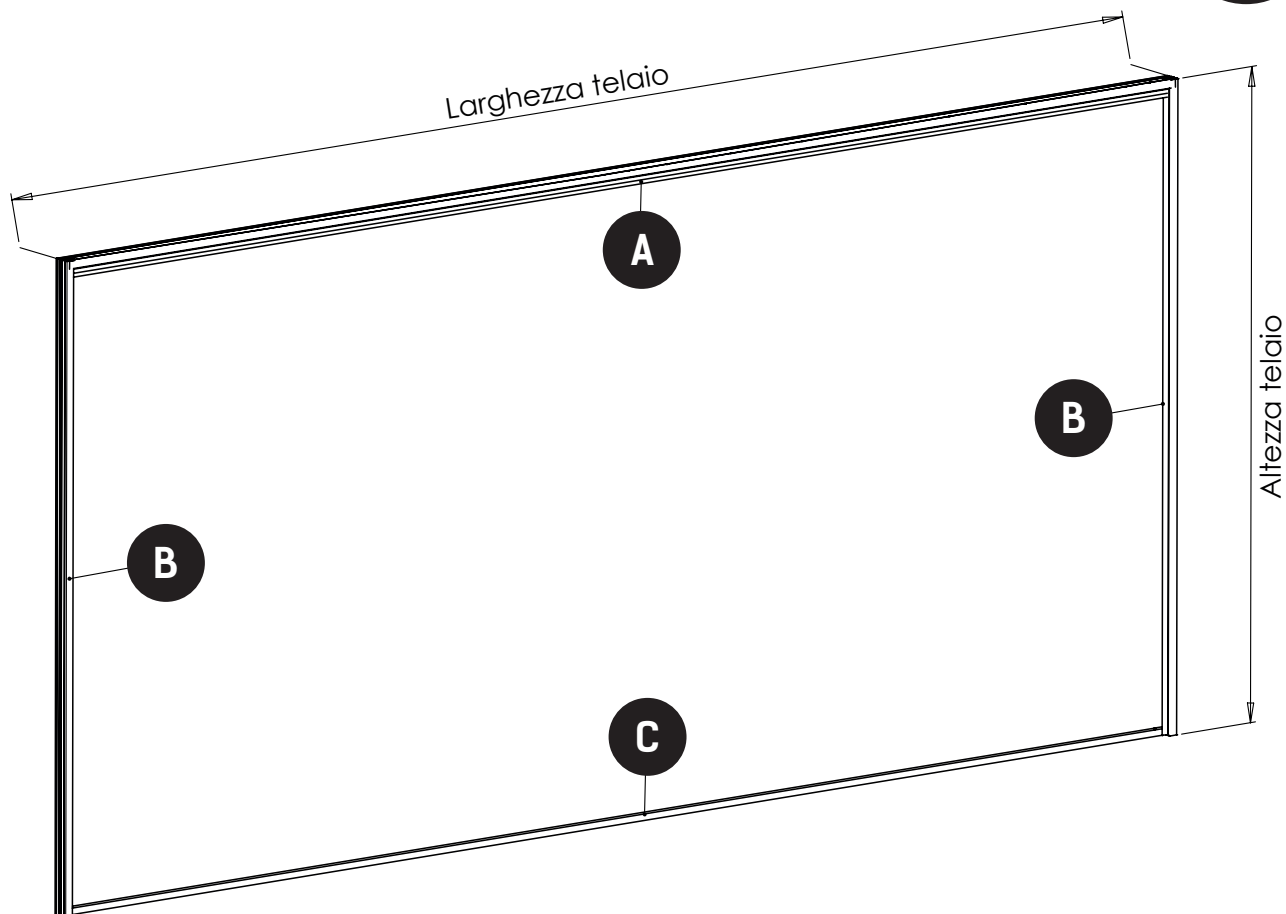

 <p><b>A</b> VR10906</p>	<p><b>Lunghezza binario superiore = Larghezza del telaio - 21 mm</b></p>
 <p><b>B</b> VR10917</p>	<p><b>Lunghezza profilo telaio laterale = Altezza telaio</b></p>
 <p><b>B</b> VR10917</p>	<p><b>OPZIONE senza lavorazione CNC</b>      <b>Con piastre di giunzione</b></p> <p><b>Lunghezza profilo telaio laterale = Altezza telaio - 62 mm</b></p> 
 <p><b>C</b> VR10926</p>	<p><b>Lunghezza guida inferiore = Larghezza del telaio - 21 mm</b></p>

# 2

## Foratura e lavorazione dei profili

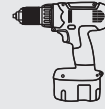

I punti di fissaggio devono essere a livello dei singoli punti.

### 2.1

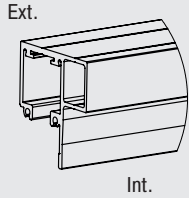

**A** VR10906

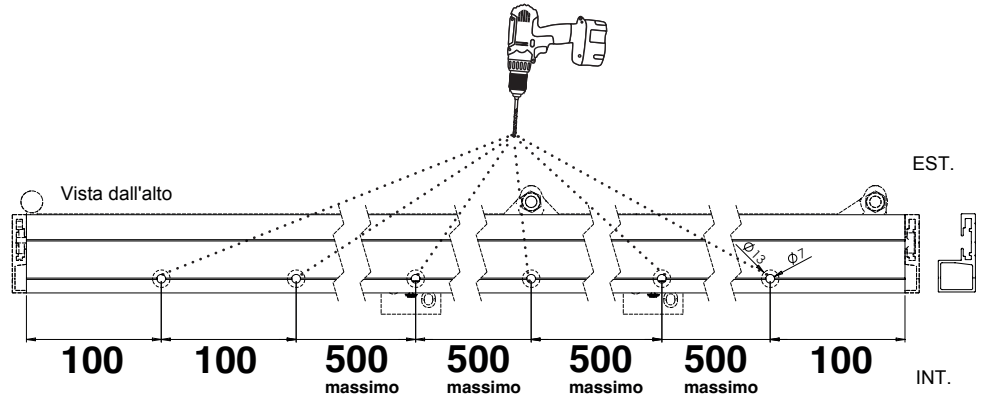

### 2.2

Prima della lavorazione

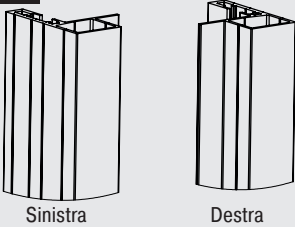

Dopo della lavorazione

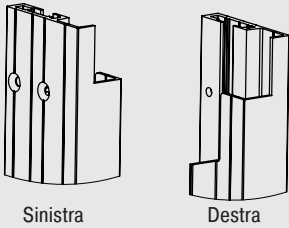

**B** VR10917

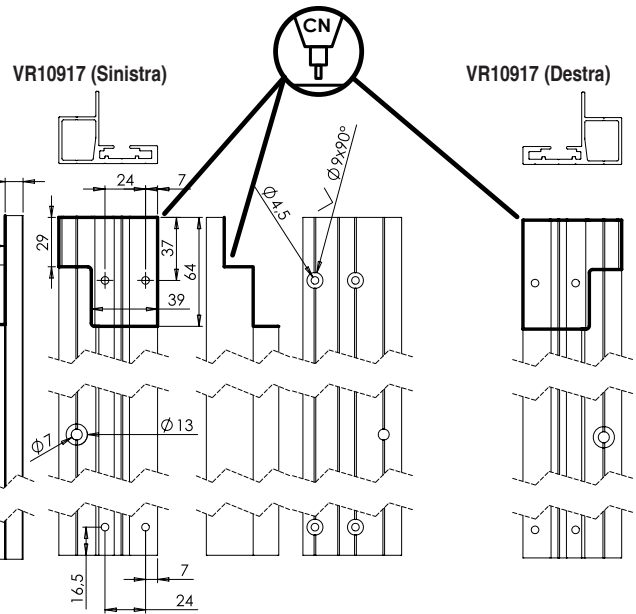
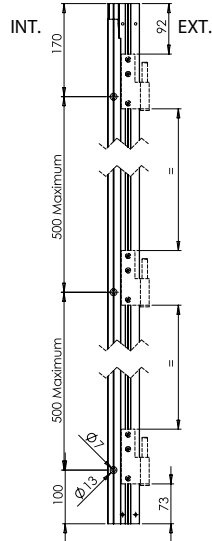

### 0

**OPZIONE senza lavorazione CNC**

**Con piastre di giunzione**

VR10917 (Sinistra)

VR10917 (Destra)

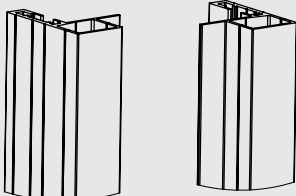

**B** VR10917



**T** VR10918

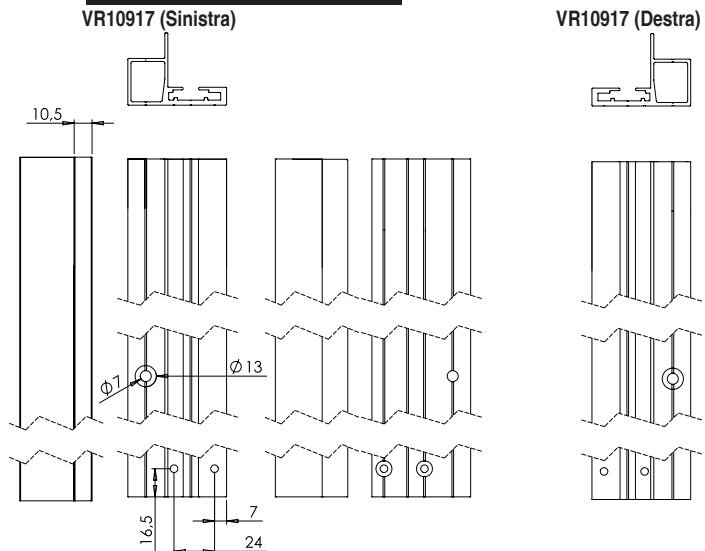
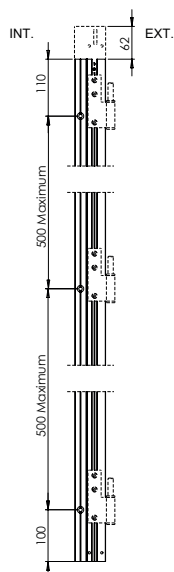

# 2

## Foratura e lavorazione dei profili

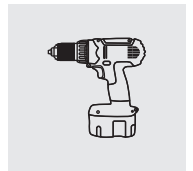

I punti di fissaggio devono essere a livello dei singoli punti.

### 2.3

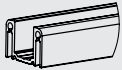

C VR10926

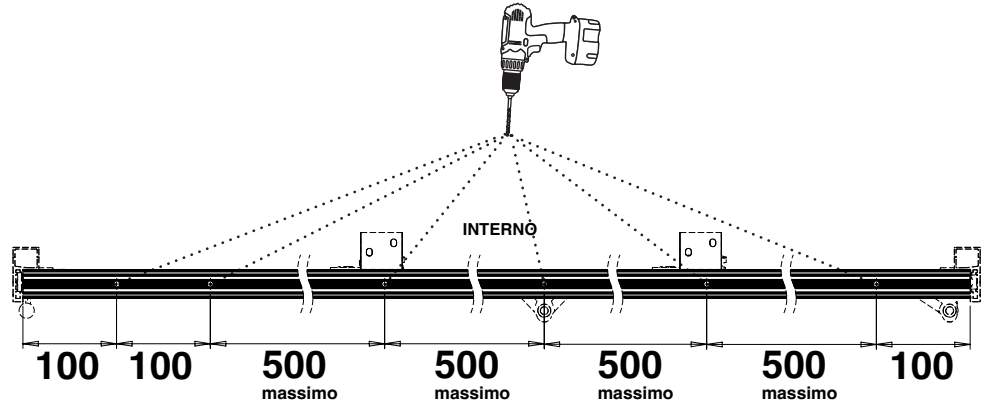

### Drenaggio del binario di guida inferiore

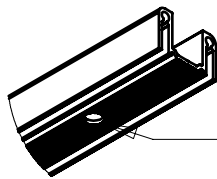
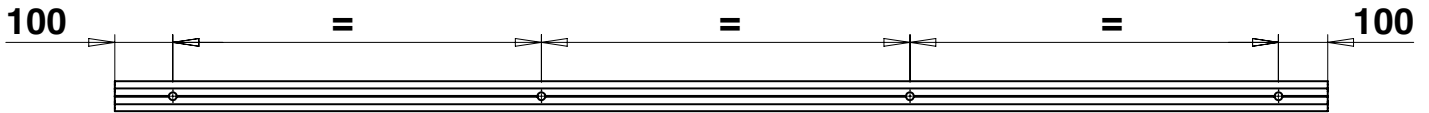
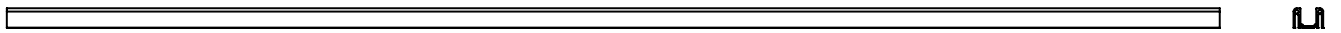

Drainage vertical Ø8

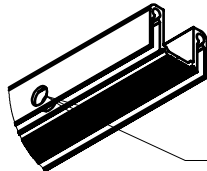

Drainage horizontal Ø8  
(orienté vers l'extérieur)

# 3 Montaggio del telaio

Configurazione  
**4 + 4**  
EST.  
INT.

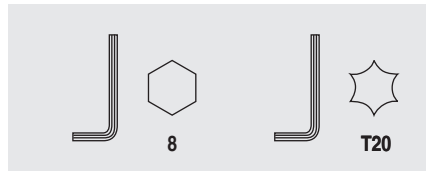

Per facilitare il montaggio e permettere la posa a terra del telaio, i passaggi qui di seguito sono orientati con vista dall'esterno.

## 3.1

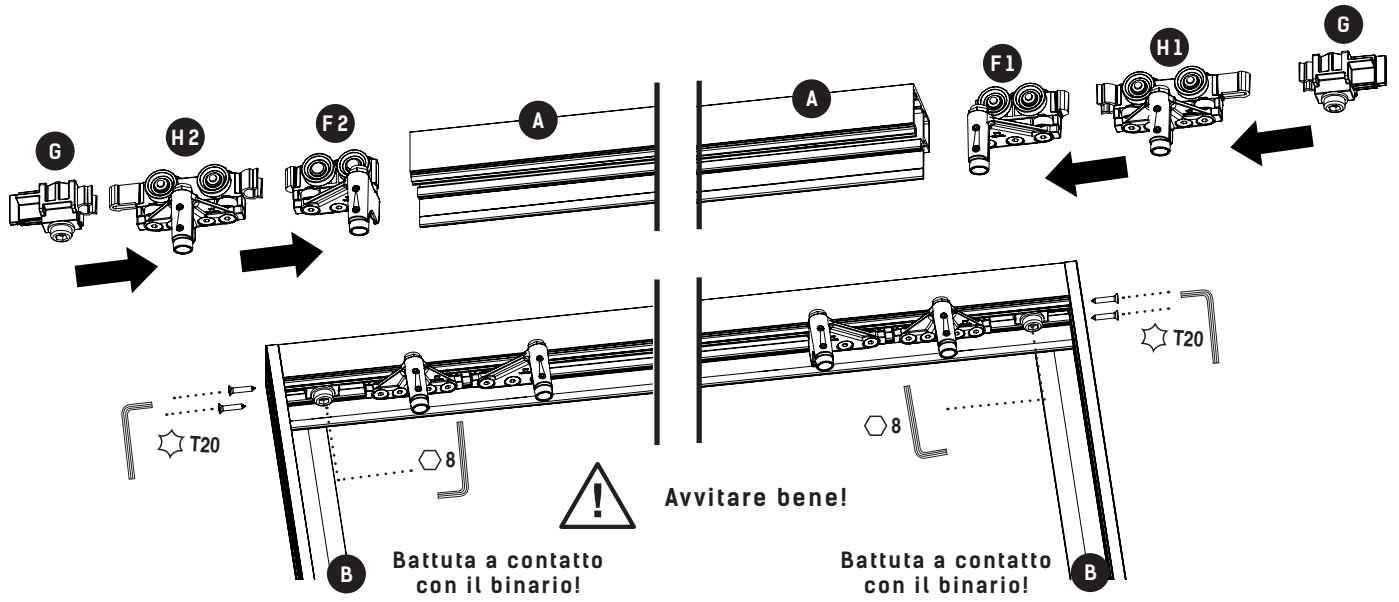
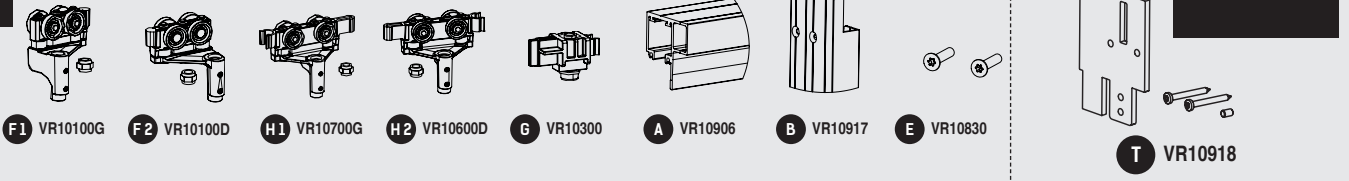

### OPZIONE senza lavorazione CNC

### Con piastre di giunzione

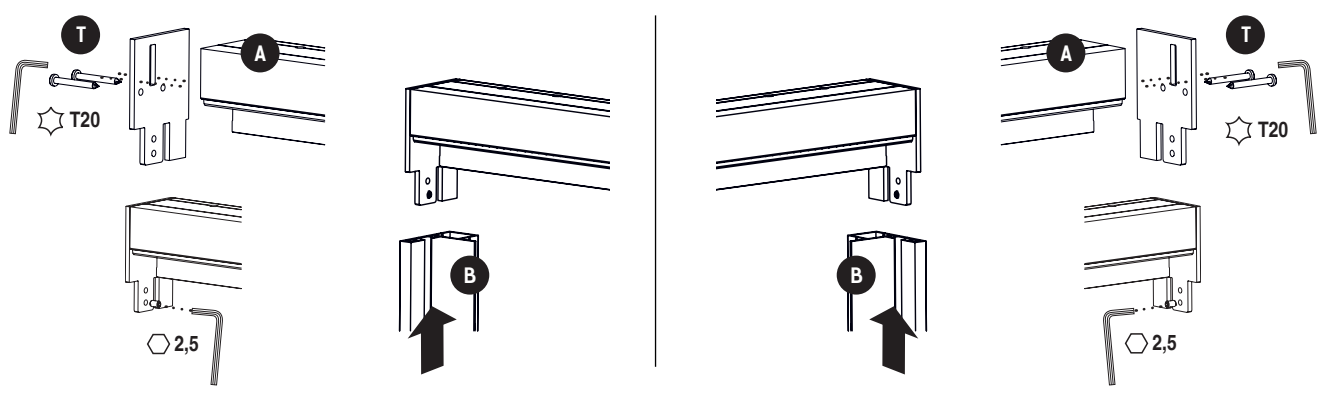

## 3.2

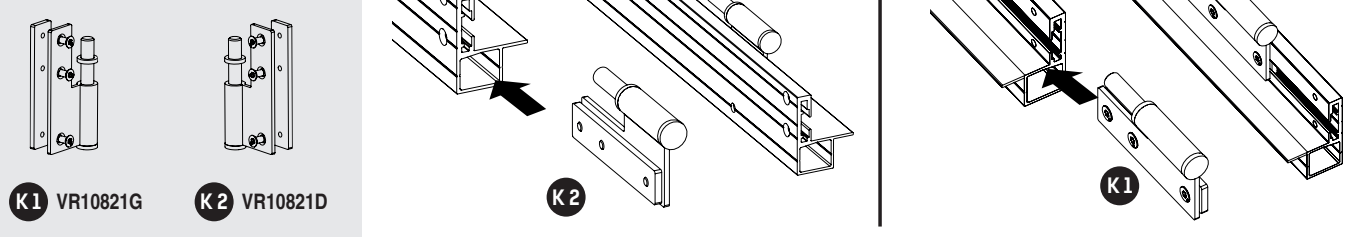

# 3 Montaggio del telaio

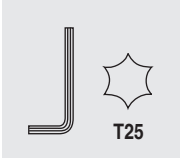

Per facilitare il montaggio e permettere la posa a terra del telaio, i passaggi qui di seguito sono orientati con vista dall'esterno.

## 3.3

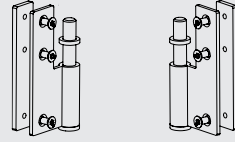

**K1** VR10821G **K2** VR10821D

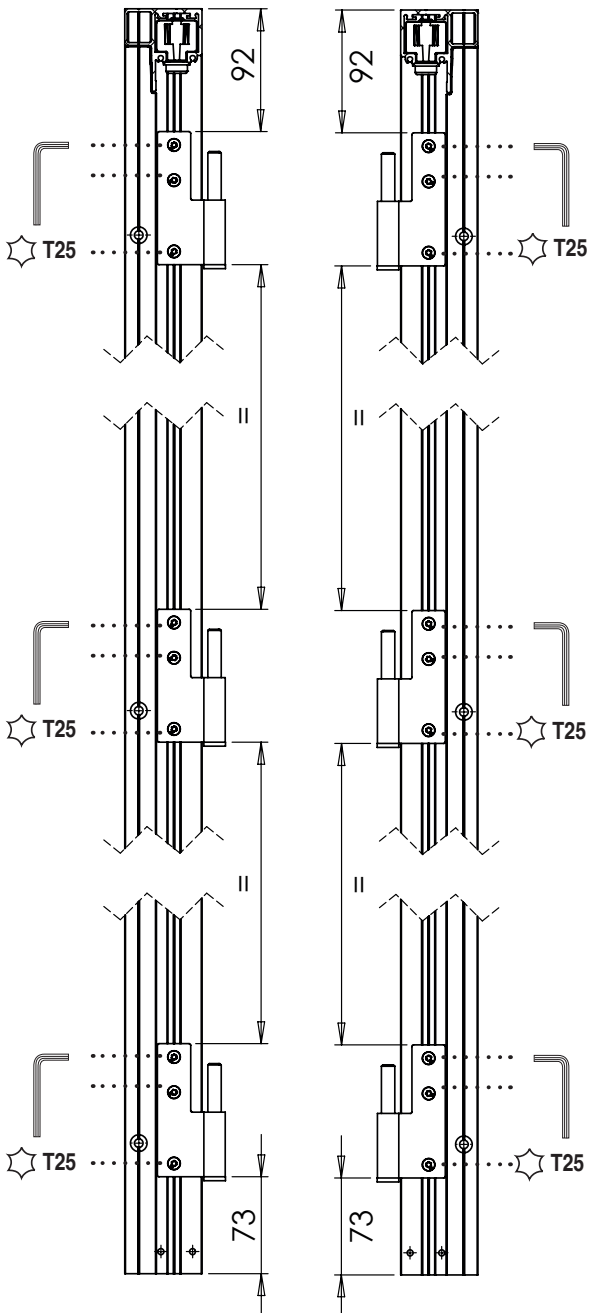

H		
< 1800 mm	1800 mm <...> 2800 mm	> 2800 mm

# 3 Montaggio del telaio

Configurazione  
**4 + 4**  
EST.  
INT.

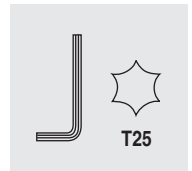

Per facilitare il montaggio e permettere la posa a terra del telaio, i passaggi qui di seguito sono orientati con vista dall'esterno.

## 3.4

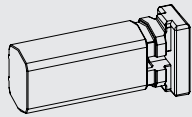

**E** VR10830

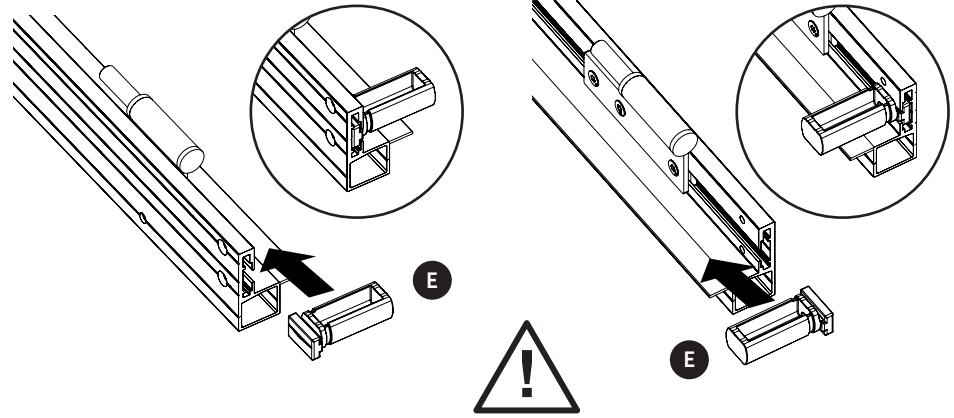

**Attenzione al senso di posa della battuta!**

## 3.5

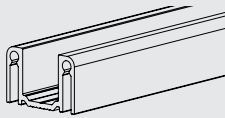

**C** VR10926

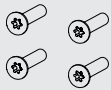

**E** VR10830

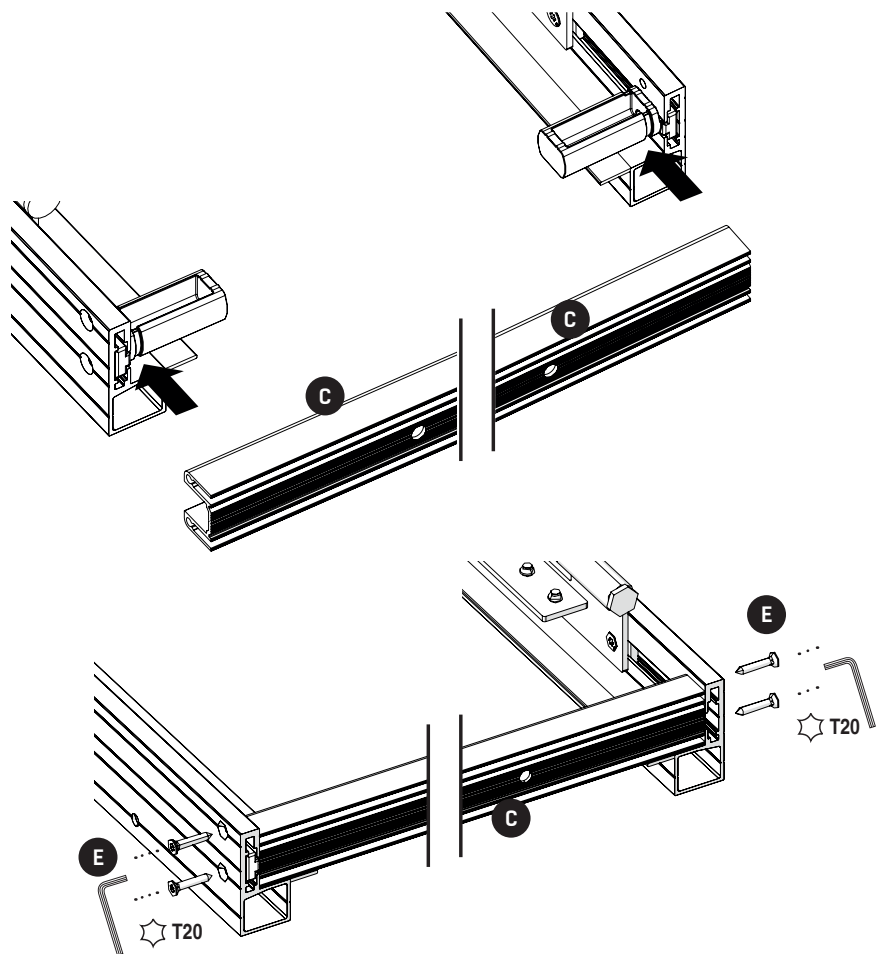

**Primo paio di ante**

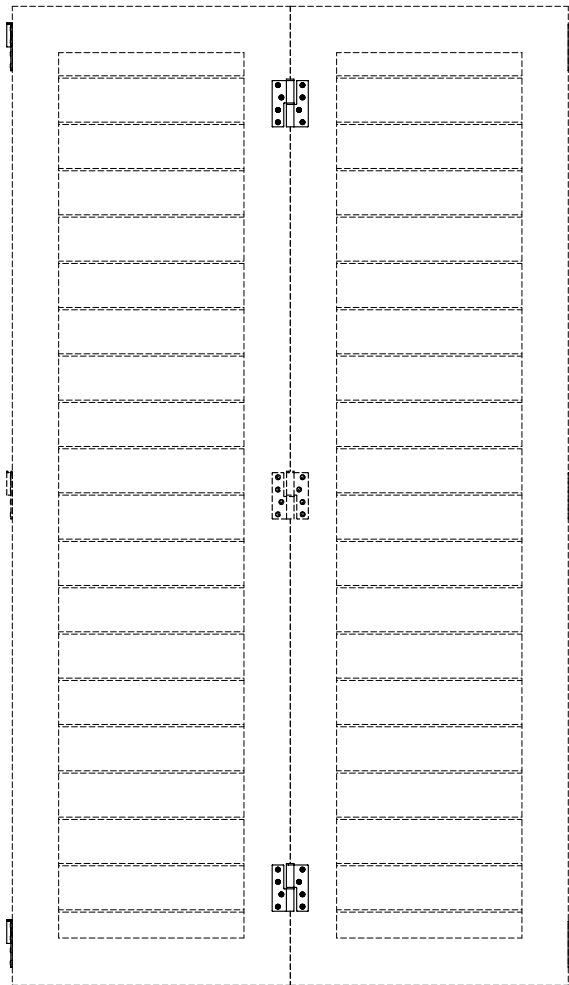

**SINISTRA**

**Secondo paio di ante**

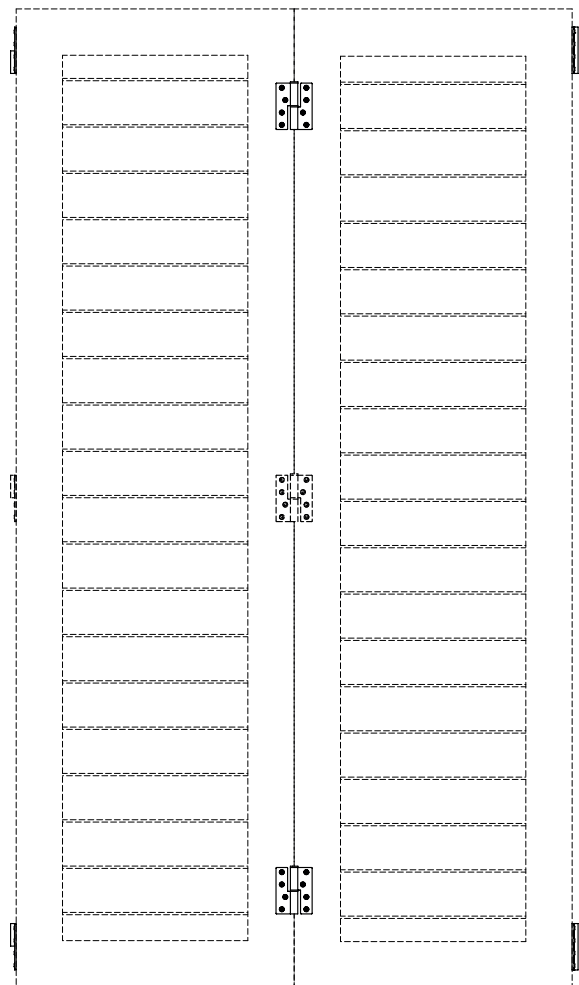

**SINISTRA**

H		
< 1800 mm	1800 mm <....> 2800 mm	> 2800 mm



## 4.2

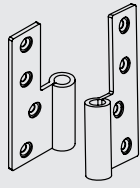

M VR10828

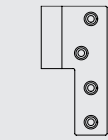
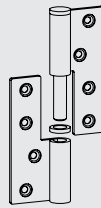
Opzionale  
se H > 1800 mm  
N1 VR10816G

L1 VR10809G

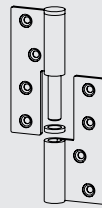

L2 VR10810D

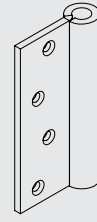

O VR10818

Vista dall'interno

Perno verso il basso!



L2

160 mini

O

39

M

39

N1

Perno verso il basso!



L1

Attenzione alla posizione  
del chiavistello!  
P.22

160 mini

Perno verso il basso!



L1

O

39

M

39

Possibilità  
di montaggio  
del chiavistello  
in officina

P. 25

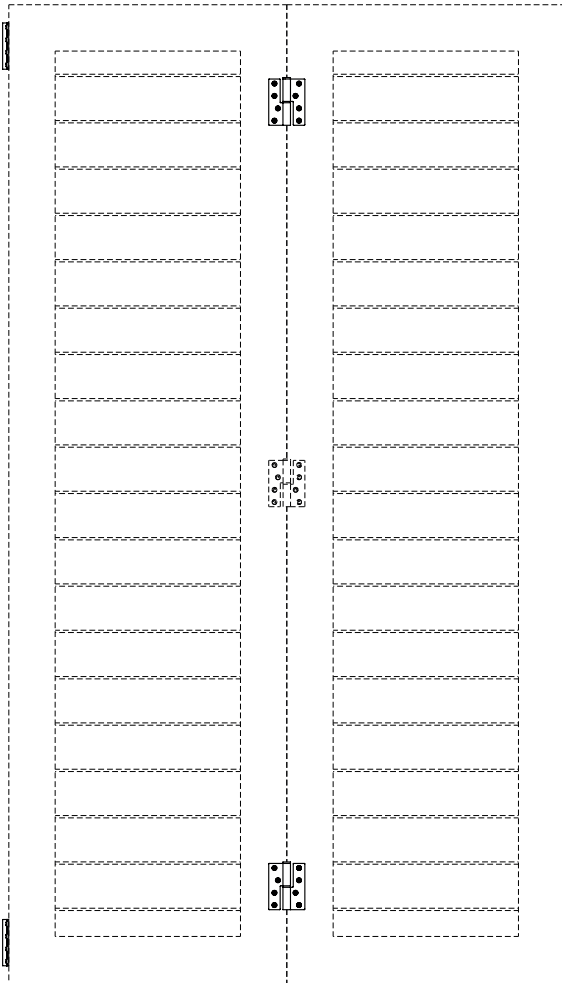
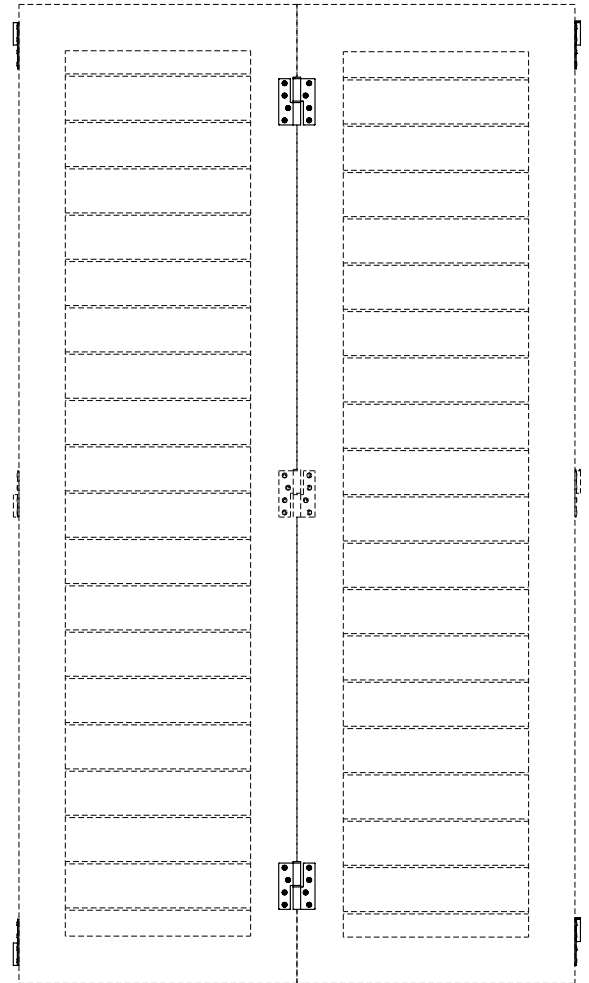
**Secondo paio  
di ante**

**DESTRA**
**Primo paio  
di ante**

**DESTRA**

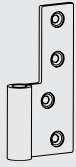
H		
< 1800 mm	1800 mm <...> 2800 mm	> 2800 mm

## 4.3



Opzionale  
se H > 1800 mm

**N2** VR10817D

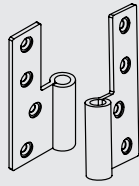

**M** VR10828

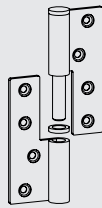

**L1** VR10809G

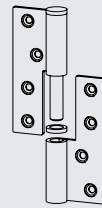

**L2** VR10810D

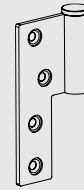

**K2** VR10822D

Vista dall'interno

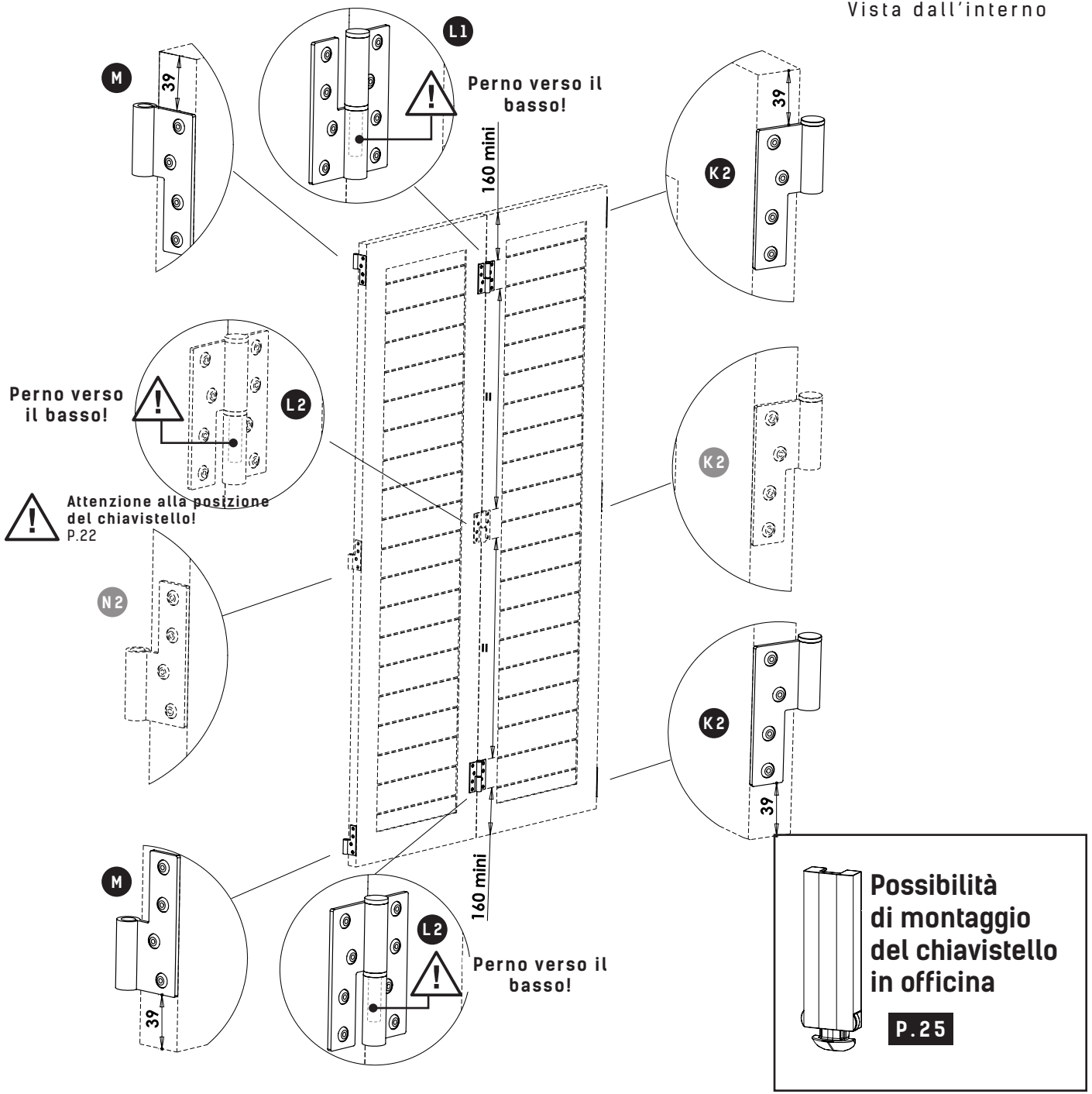

## 4.4

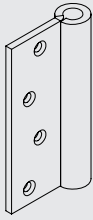

O VR10818

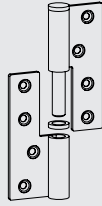

L1 VR10809G

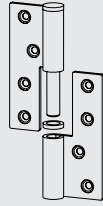

L2 VR10810D

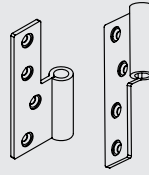

M VR10828

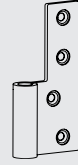
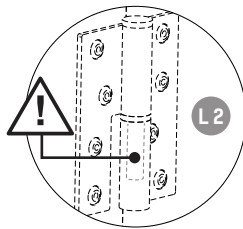
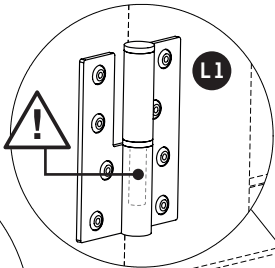
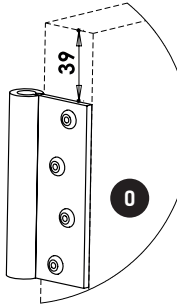
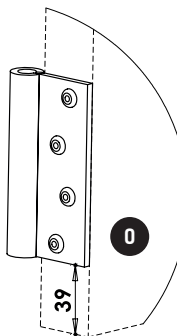
Opzionale  
se H > 1800 mm  
N2 VR10817DPerno verso il  
basso!Perno  
verso il  
basso!

160 mini

160 mini

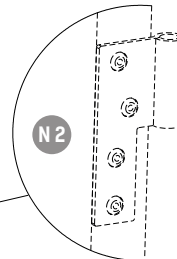
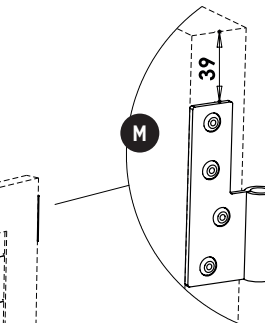
Perno  
verso il  
basso!

Attenzione alla posizione  
del chiavistello!  
P.22

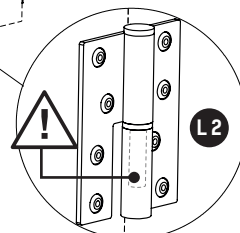
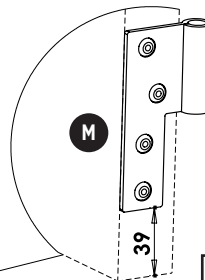

Vista dall'interno

Possibilità  
di montaggio  
del chiavistello  
in officina

P. 25

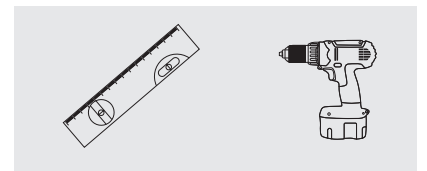

## 5 Installazione del telaio (regolazione geometrie e calibrzione)

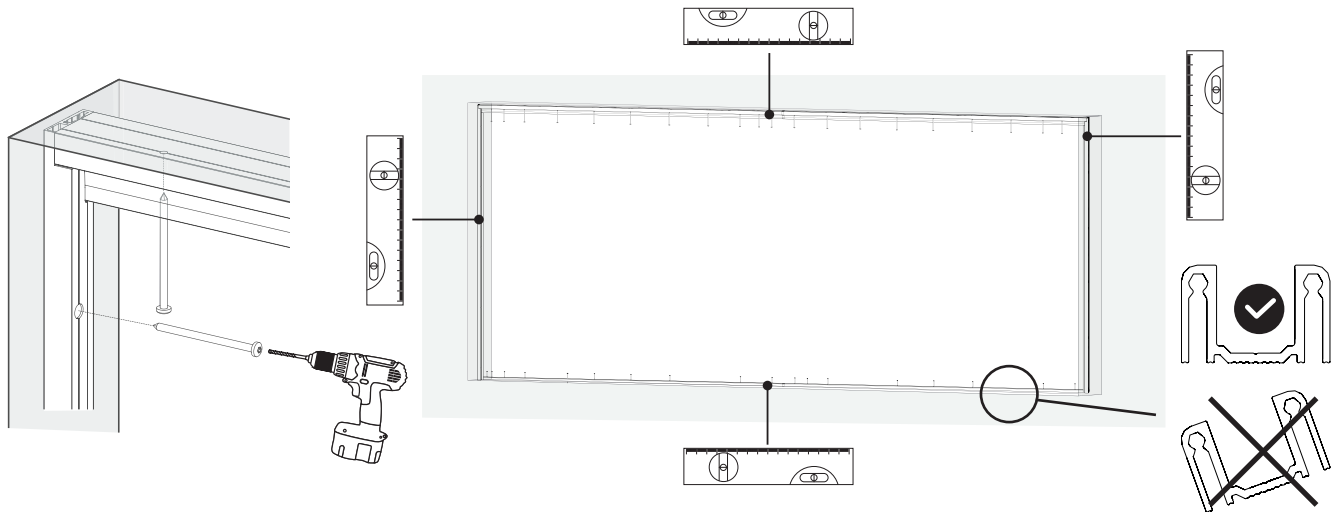

## 6 Montaggio delle ante

Vista dall'interno

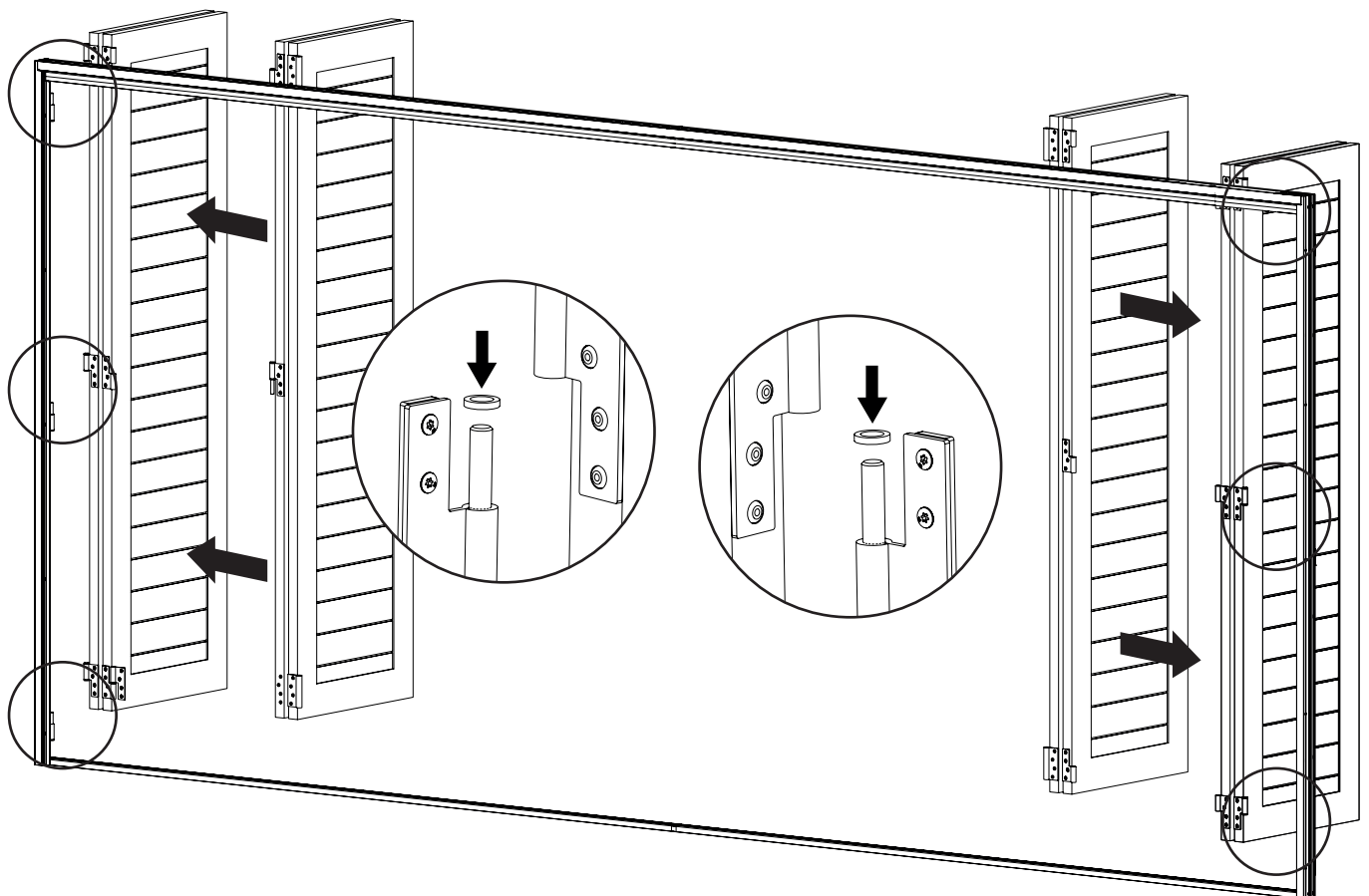

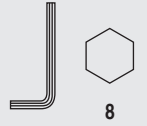

## 7.1

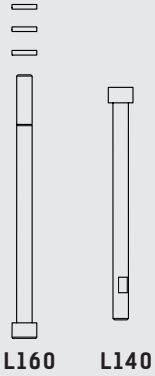

**M** VR10828

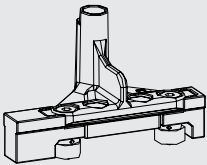

**J1** VR10800G

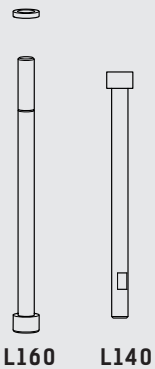

**O** VR10818

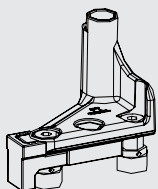

**I1** VR10400G

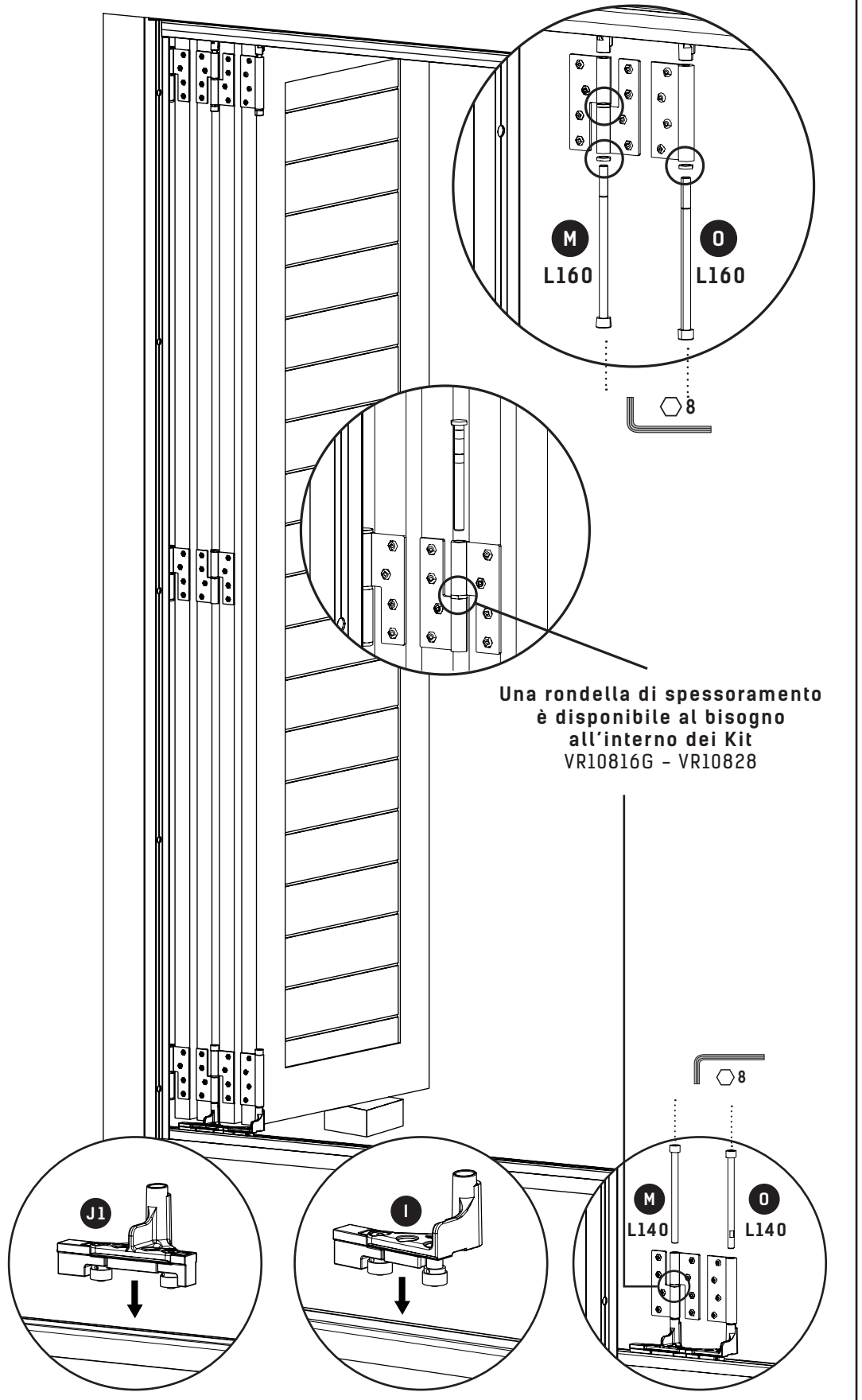

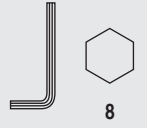

## 7.2

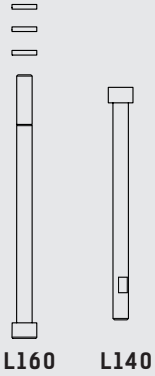

**M** VR10828

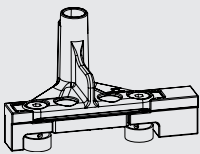

**J2** VR10801D

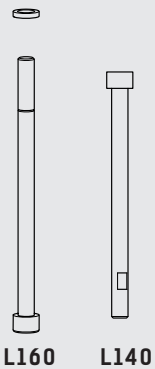

**O** VR10818

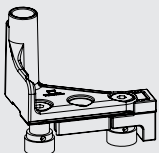

**I2** VR10500D

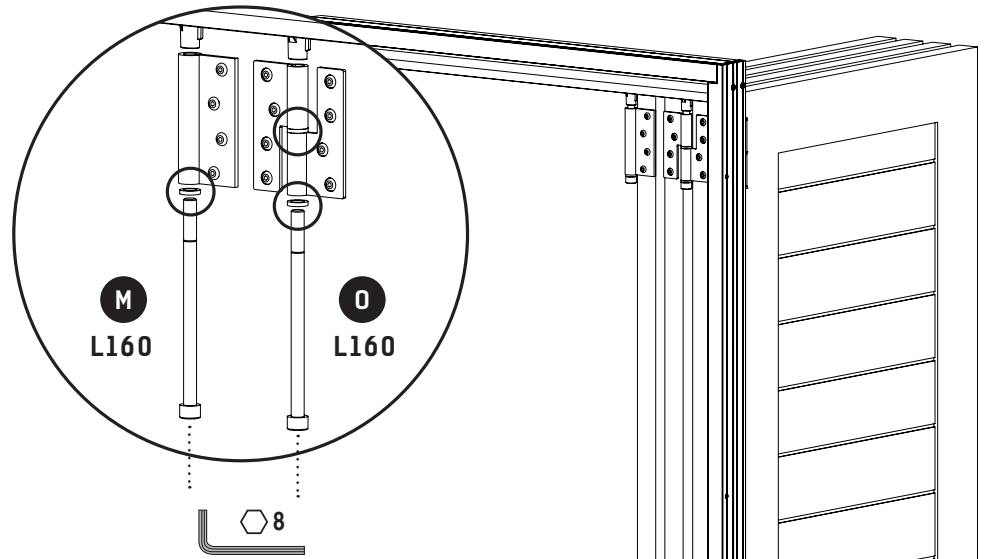

Una rondella di spessoramento  
è disponibile al bisogno  
all'interno dei Kit  
VR10816G - VR10828

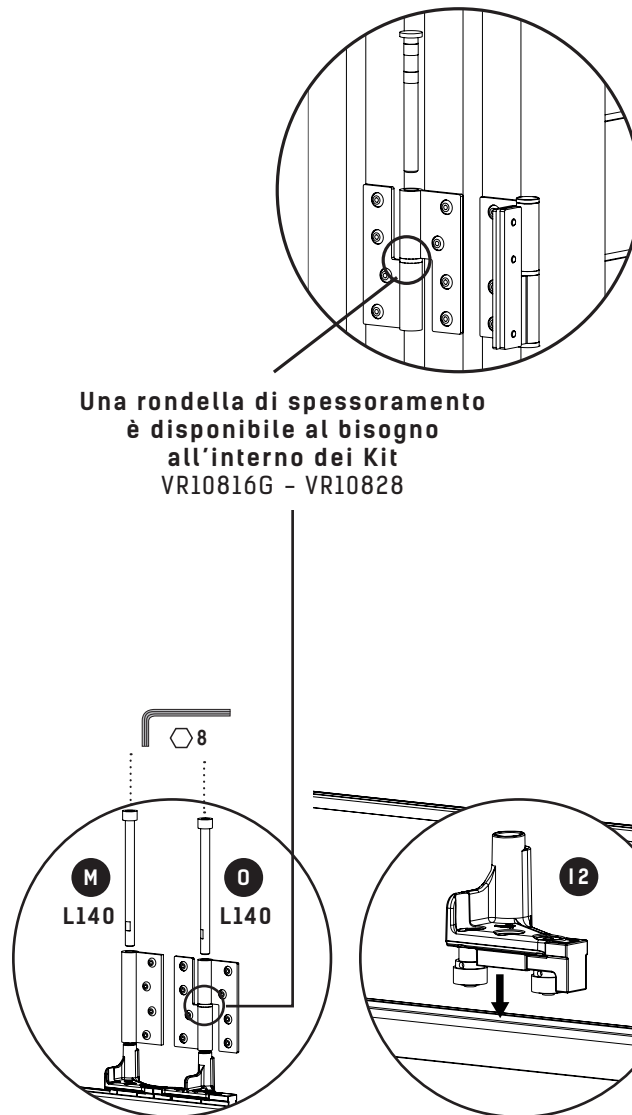

## 8.1

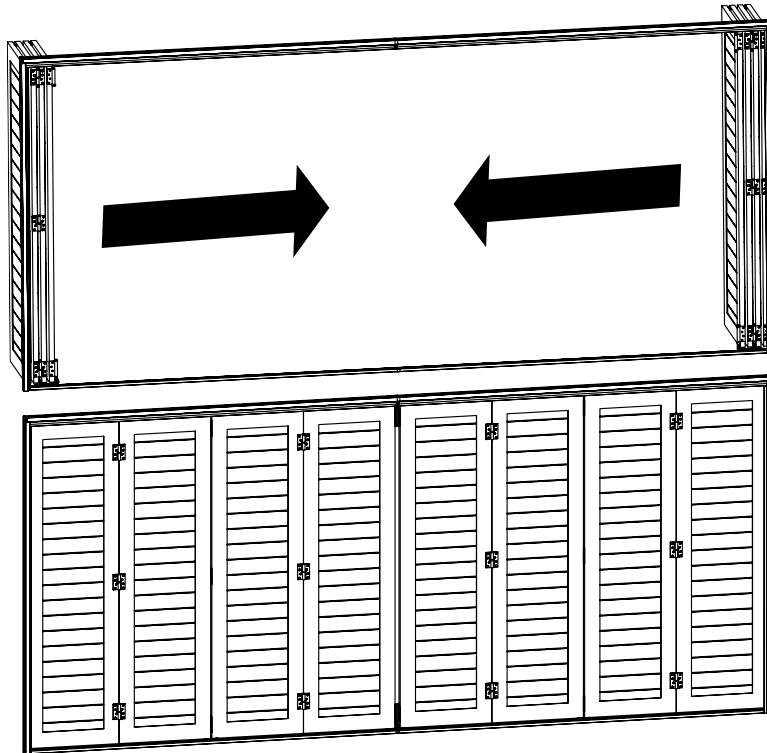

## 8.2



Verificare che la parte alta dello sbordo della ruota sia dentro il binario di 5mm per garantire una presa ottimale.

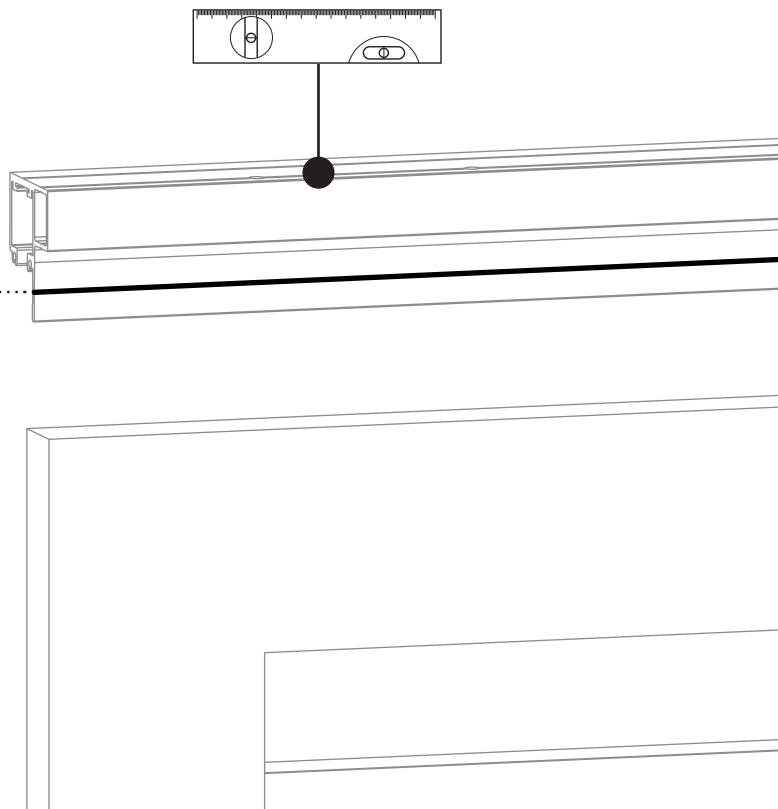

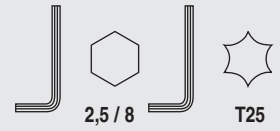

## 8.3

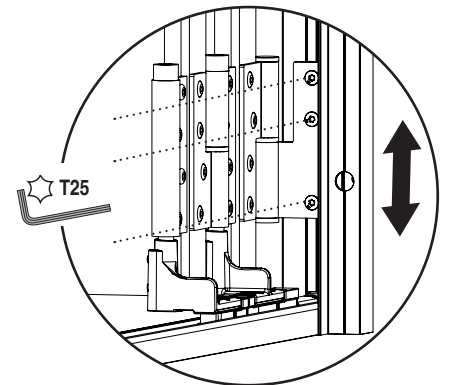
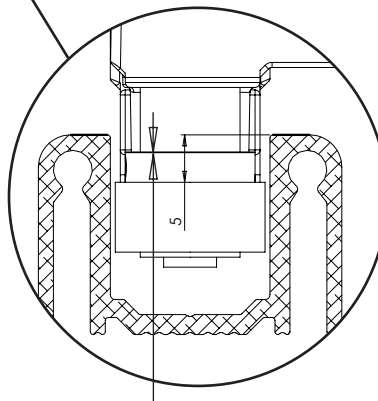
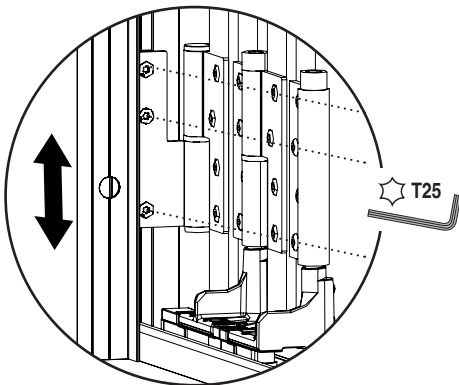
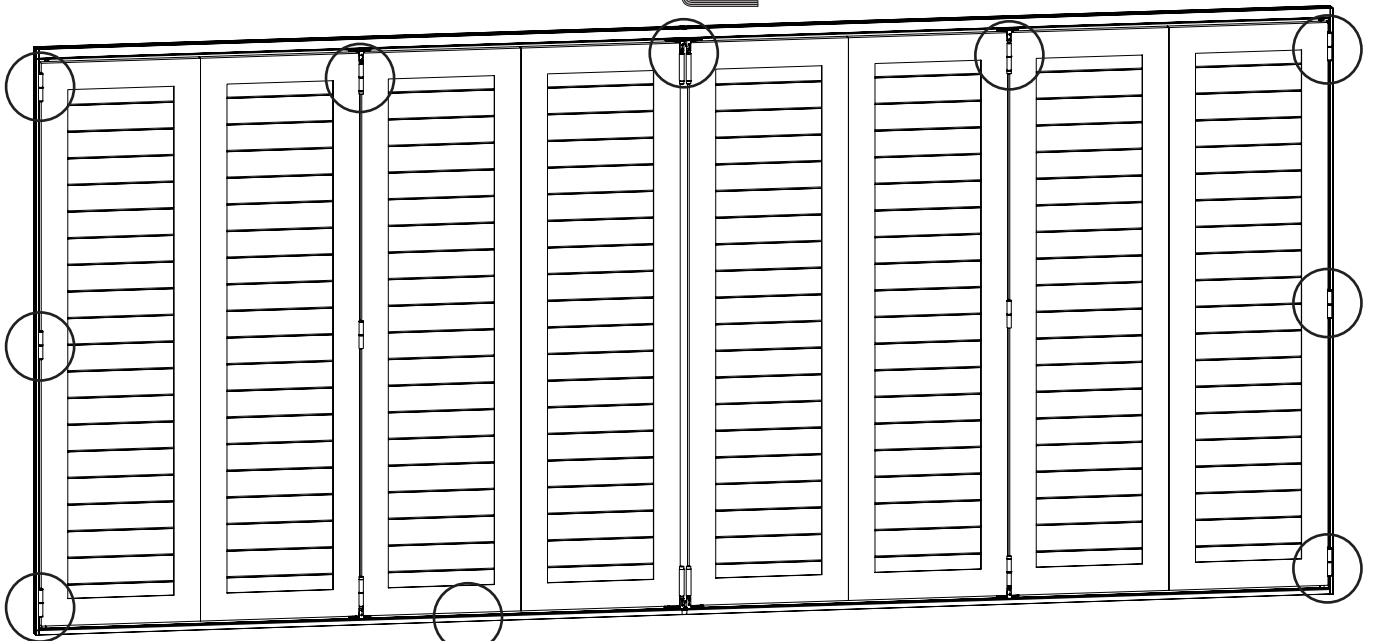
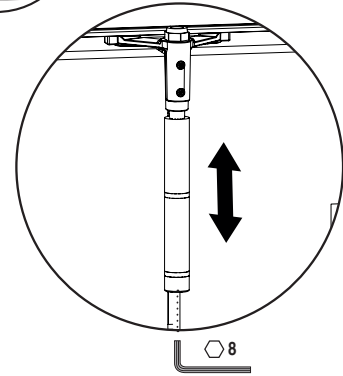
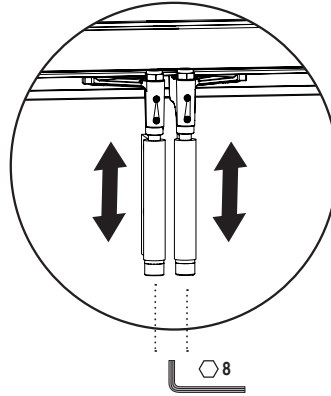
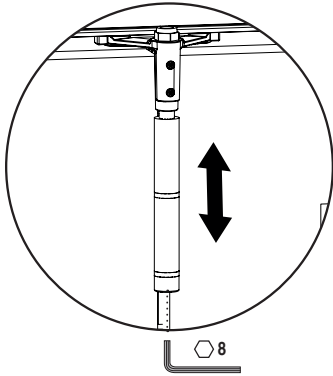
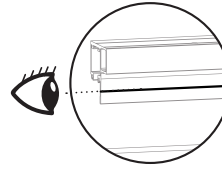

Verificare che la parte alta dello sbordo della ruota sia dentro il binario di 5mm per garantire una presa ottimale.



## 8.4

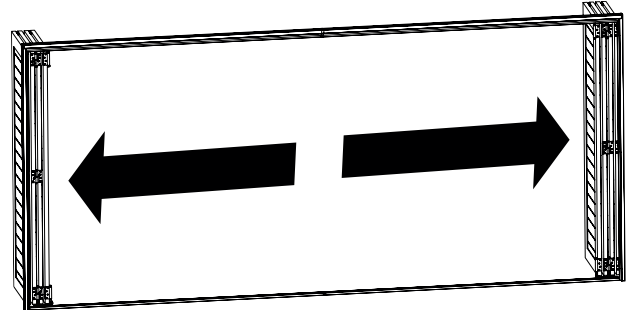
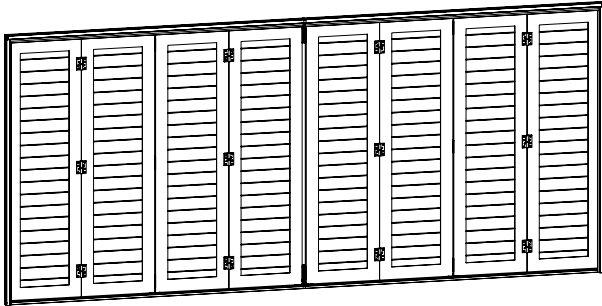

## Fissaggio di sicurezza

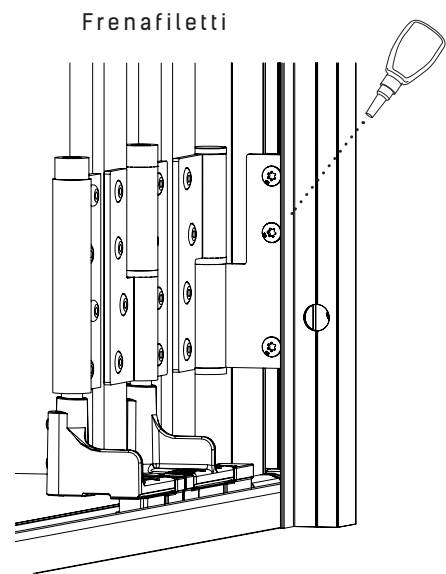
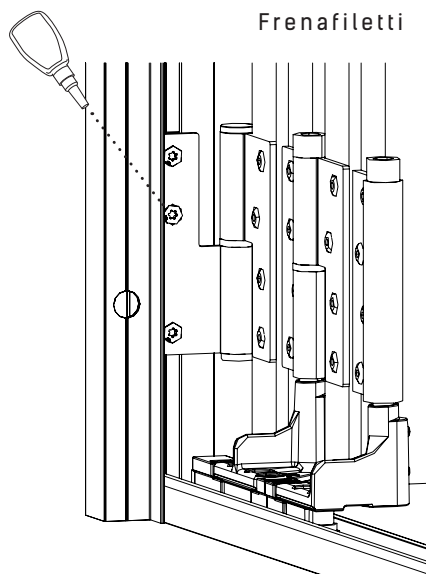
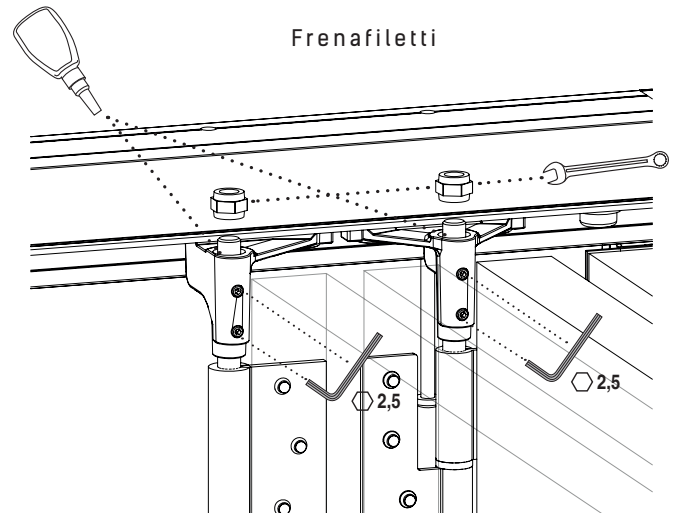
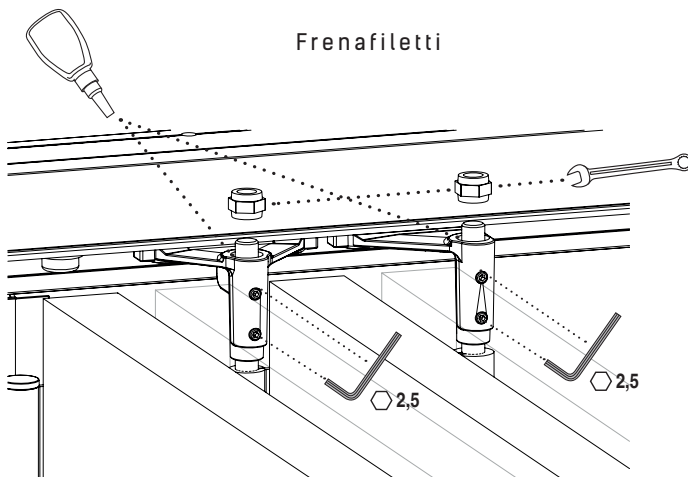

9.1

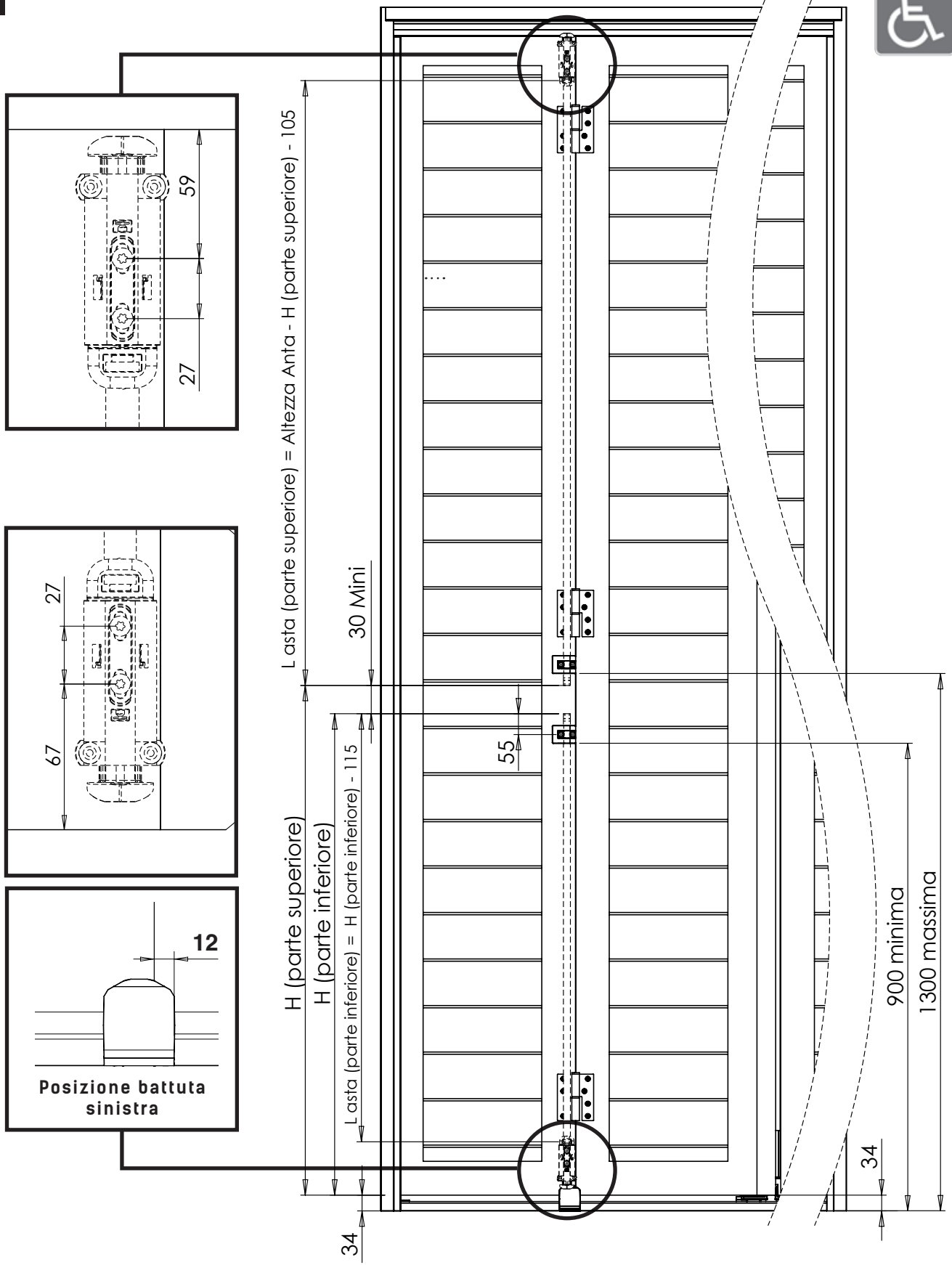

# 9

## Montaggio del chiavistello e della battuta

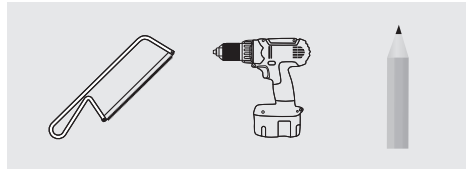

### 9.2

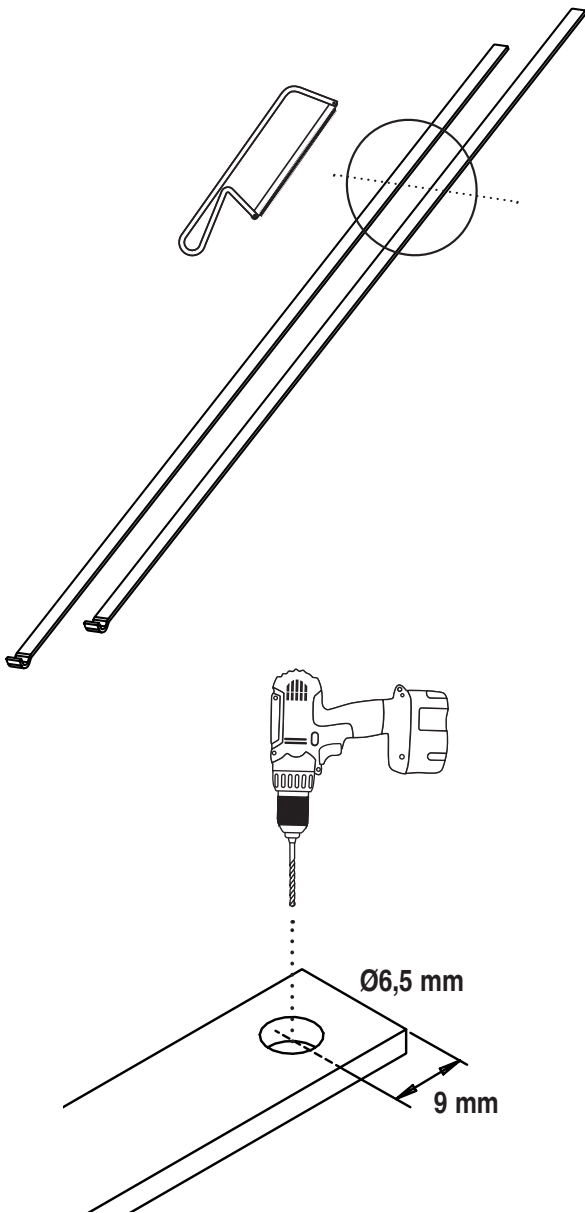
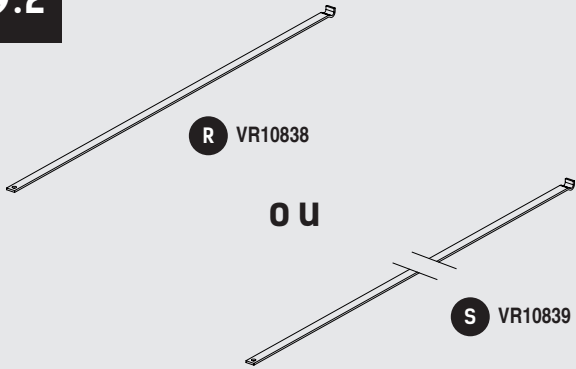

### 9.3

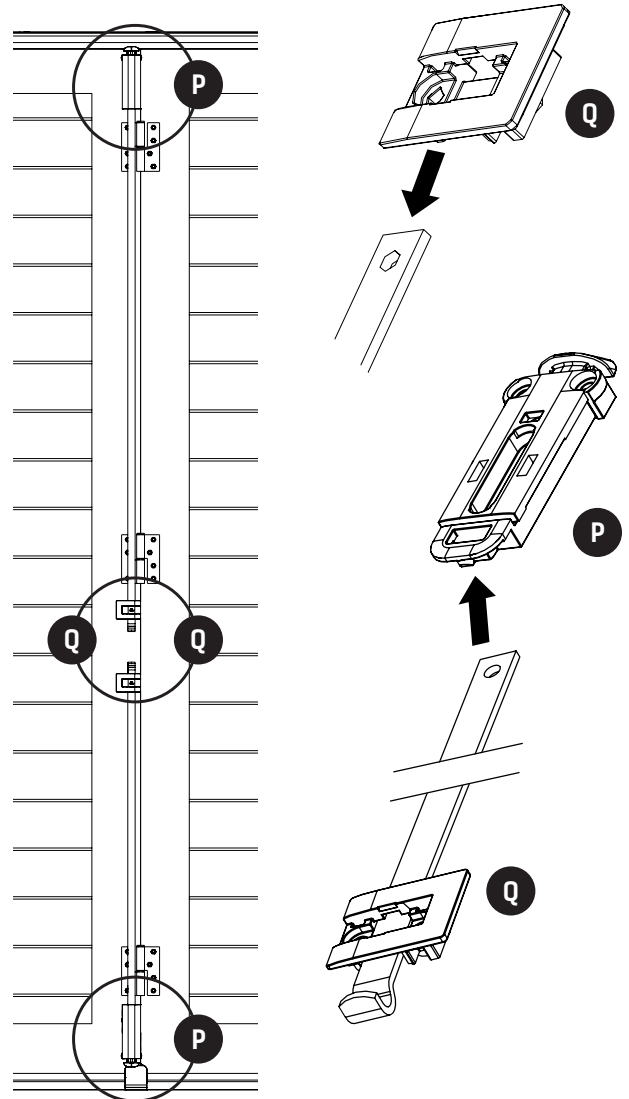
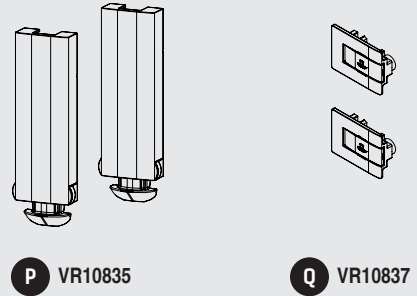

# 9

## Montaggio del chiavistello e della battuta

Configurazione  
**4 + 4**  
EST.  
INT.

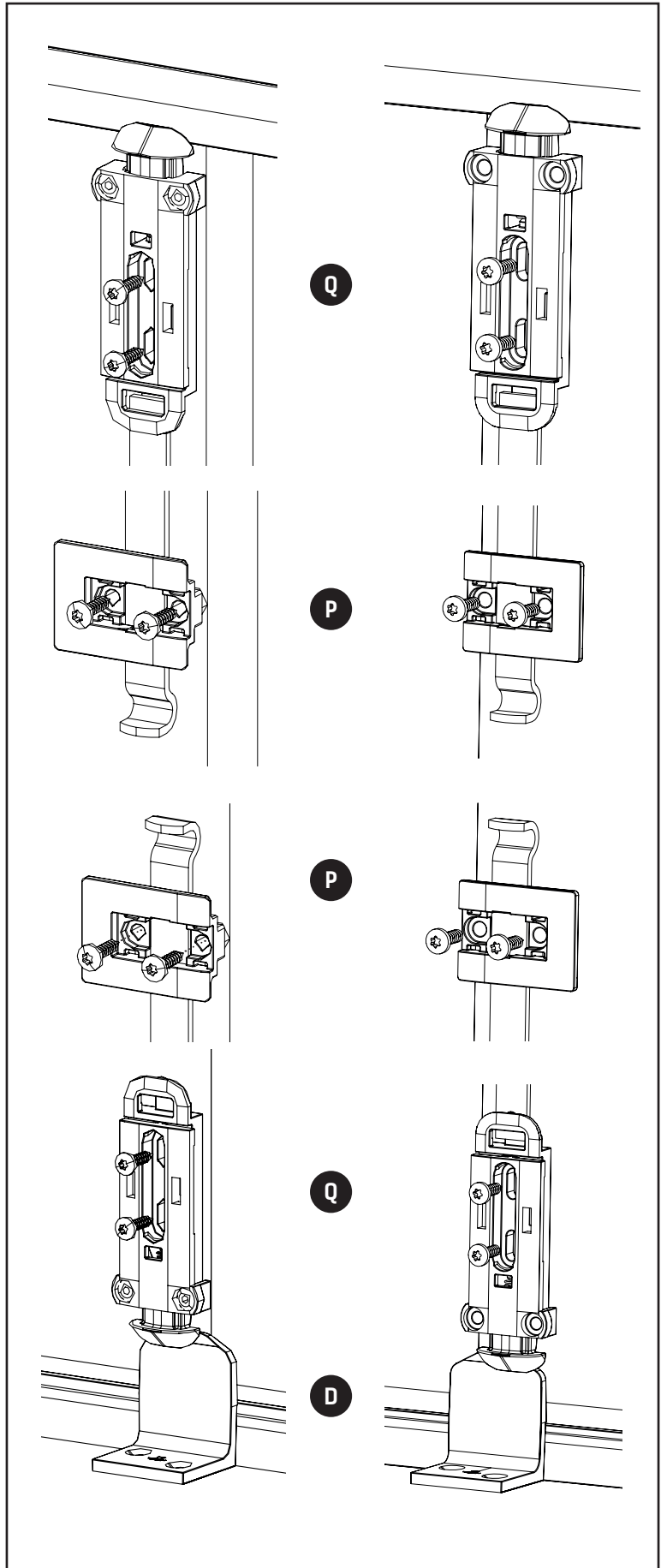
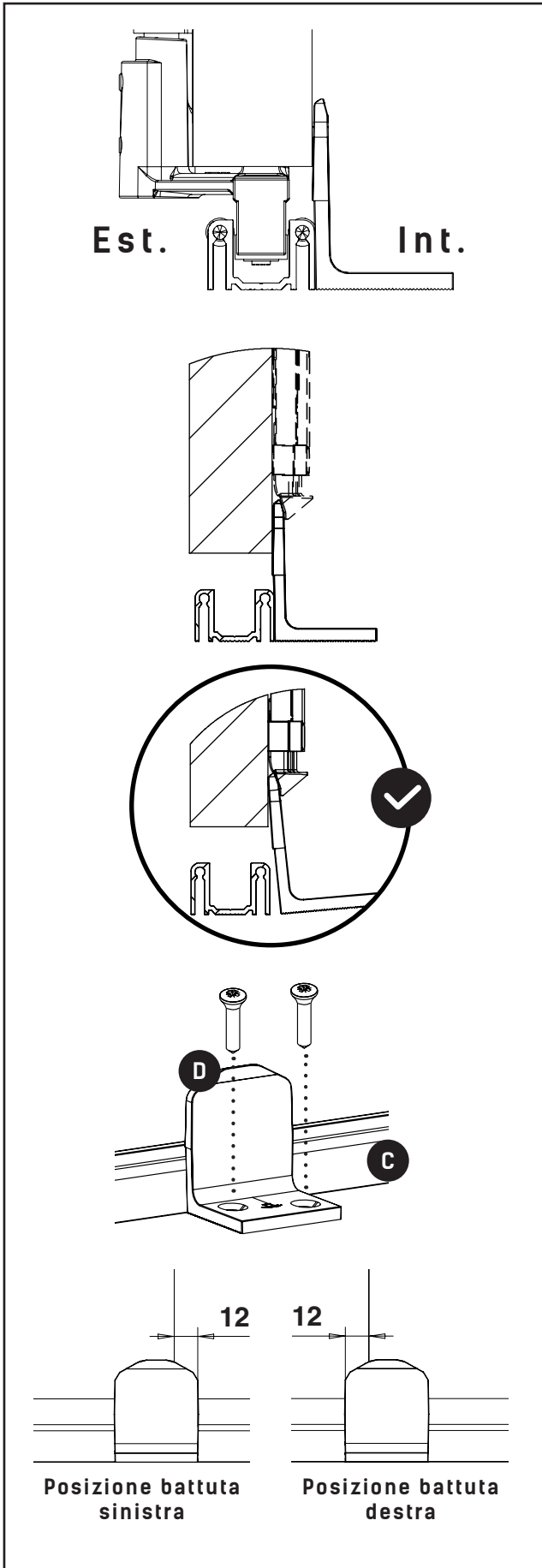
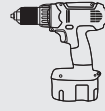

# 9

## Montaggio del chiavistello e della battuta

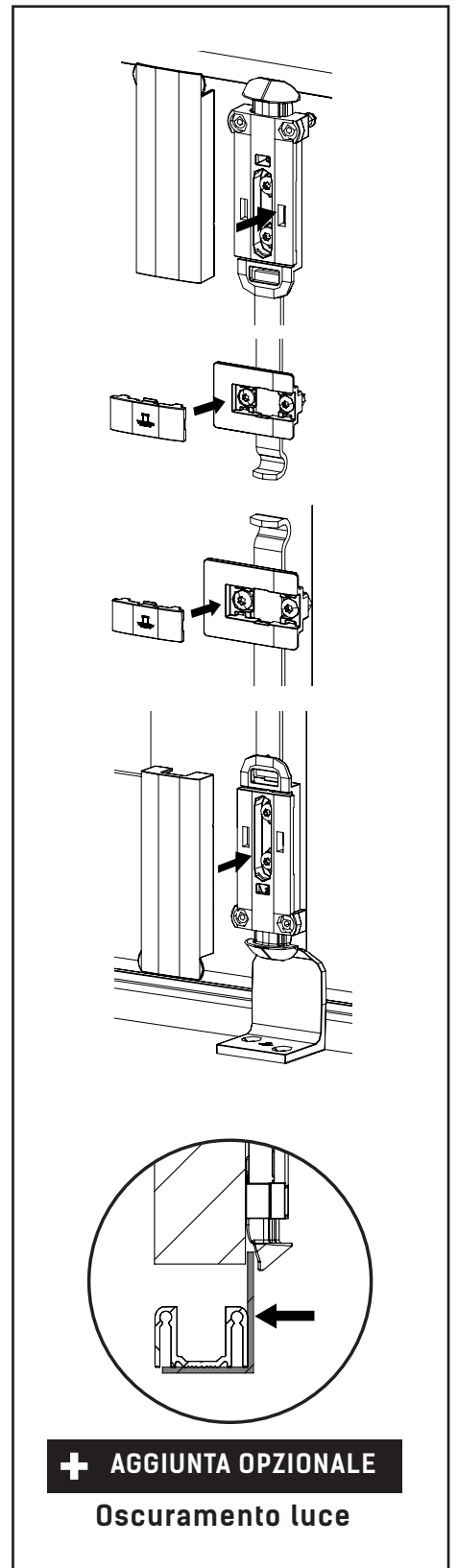
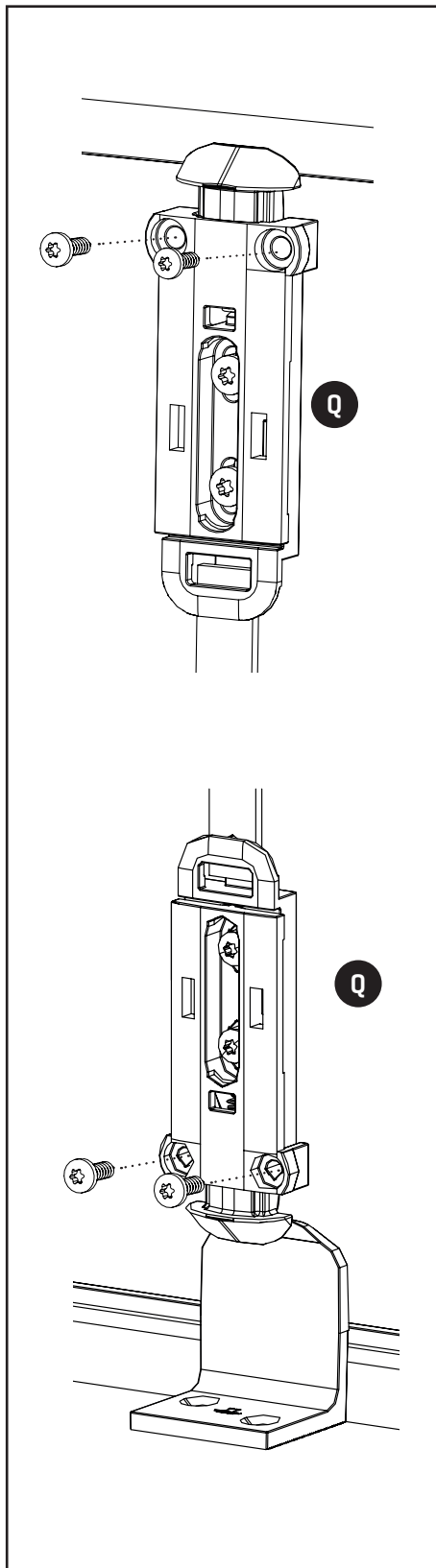
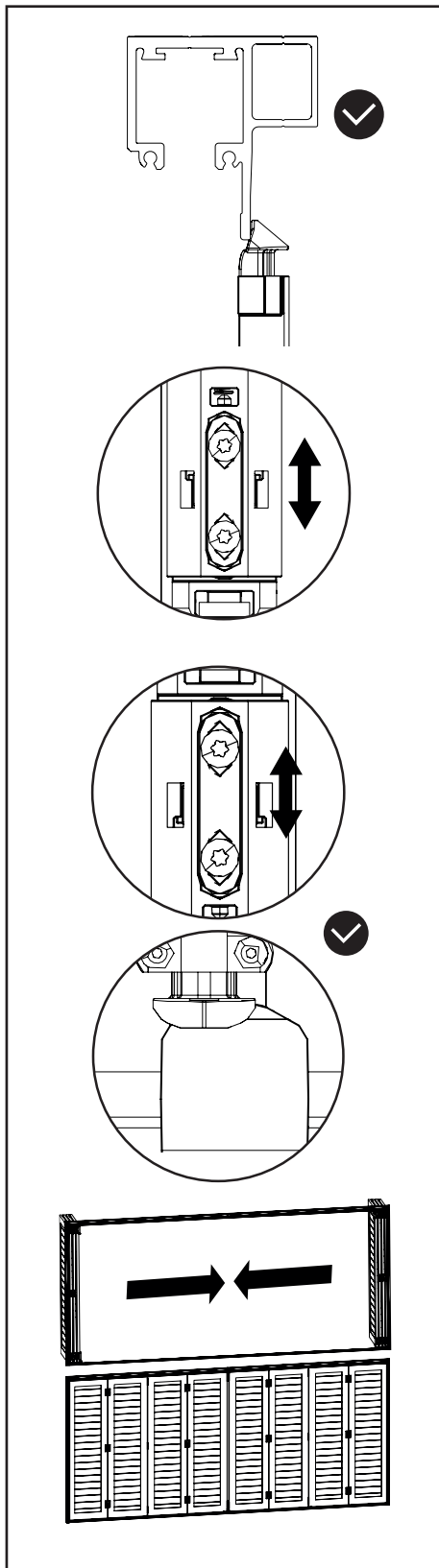
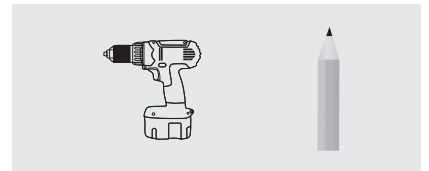

**+ AGGIUNTA OPZIONALE**  
**Oscuramento luce**

✓ **L'installazione è completata !**

**TORBEL® SRL**

Via Brandizzo, 121/G - 10088 Volpiano (TO)  
 Tel : +39 011 995 56 12 - info@torbel.it - www.torbel.it

